

**PROJECT DESCRIPTION:**

**CREATOR:** HAYL KHADHAMI  
**CHECKER:** MAJED AL-BORAEI  
**APPROVER:** TECHNOD

**COMMISSION:** TECHNOD ENGINEERING  
**DATE:** 12/23/2018  
**PAGE NO:** 1

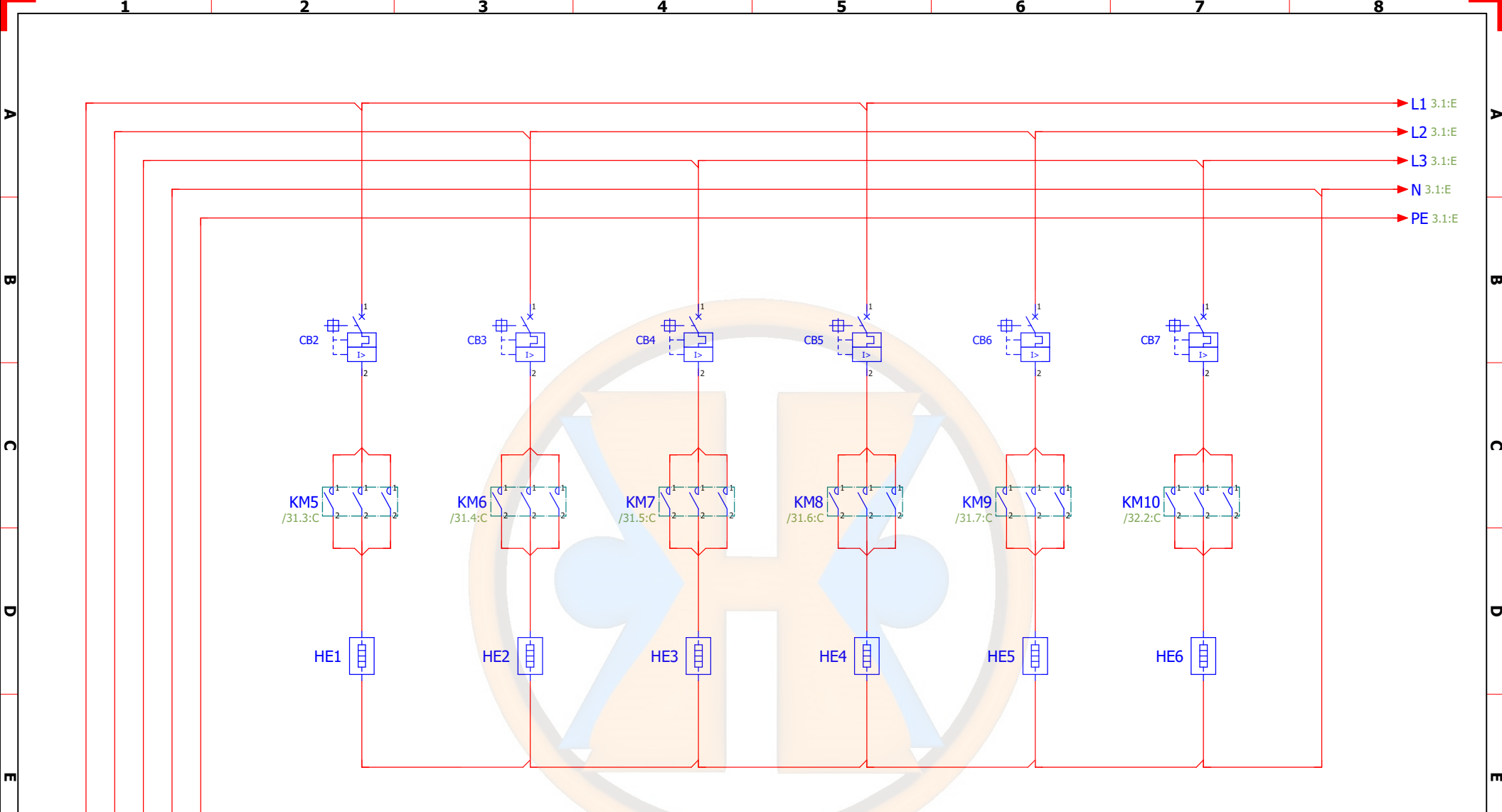



L1 L2 L3 N PE  
1.8:A 1.8:A 1.8:A 1.8:A 1.8:A

### HEATER ELEMENTS

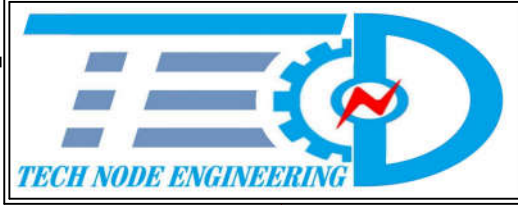

**PROJECT DESCRIPTION:**

**CREATOR:** HAYL KHADHAMI

**COMMISSION:** TECHNOD ENGINEERING

**CHECKER:** MAJED AL-BORAEI



**APPROVER:** TECHNOD

**DATE:** 12/23/2018

**PAGE NO:** 2

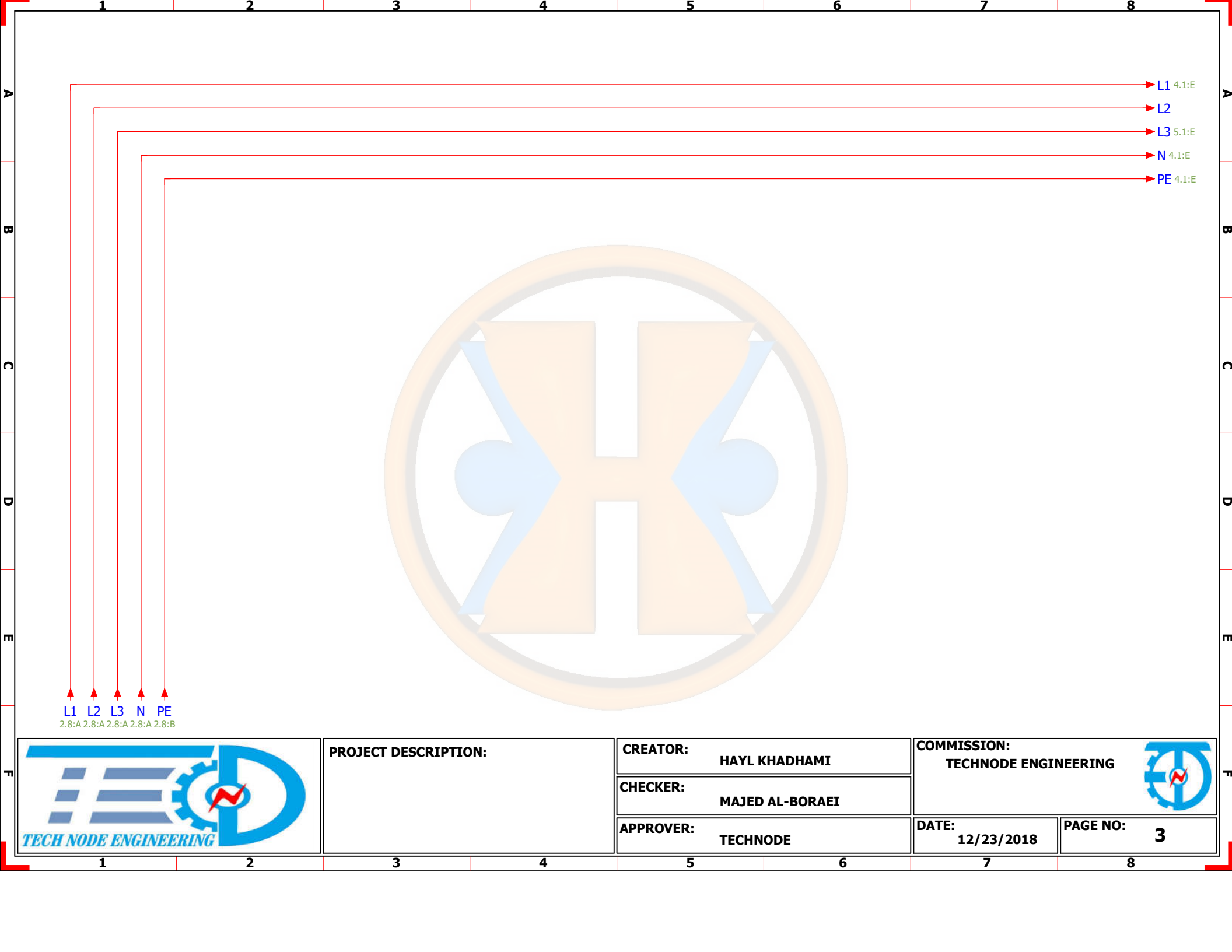

L1 4.1:E  
 L2  
 L3 5.1:E  
 N 4.1:E  
 PE 4.1:E

L1 L2 L3 N PE  
 2.8:A 2.8:A 2.8:A 2.8:A 2.8:B

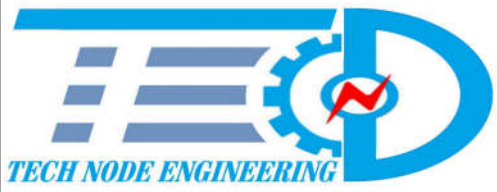

**PROJECT DESCRIPTION:**

**CREATOR:** HAYL KHADHAMI  
**CHECKER:** MAJED AL-BORAEI  
**APPROVER:** TECHNODE

**COMMISSION:** TECHNODE ENGINEERING   
**DATE:** 12/23/2018  
**PAGE NO:** 3

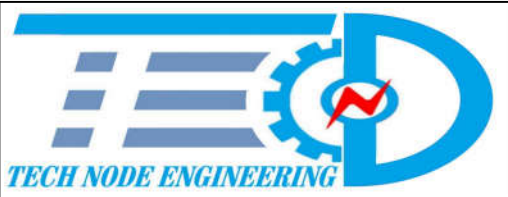
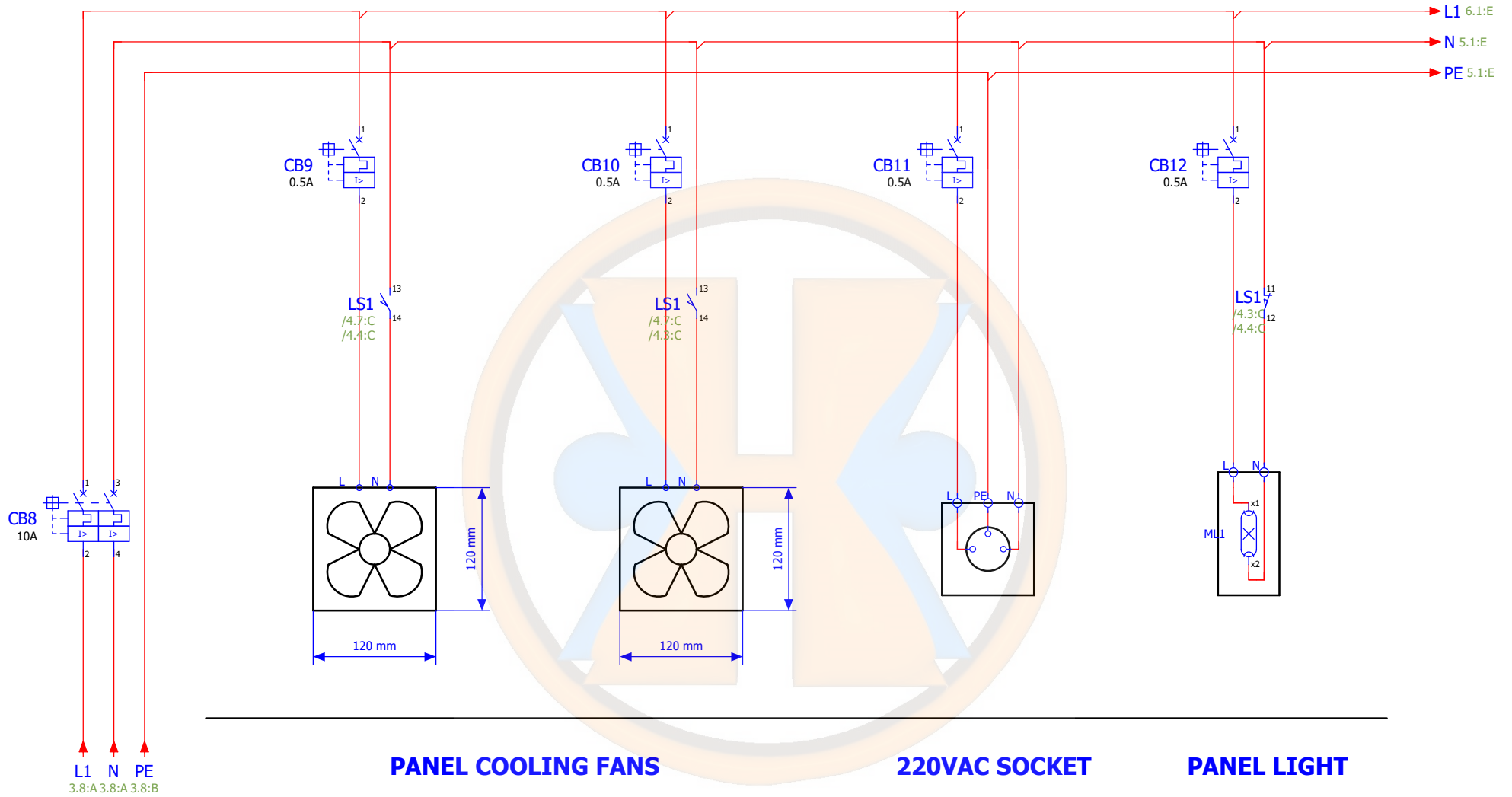

**PROJECT DESCRIPTION:**

**CREATOR:** HAYL KHADHAMI  
**CHECKER:** MAJED AL-BORAEI  
**APPROVER:** TECHNOD

**COMMISSION:** TECHNOD ENGINEERING

**DATE:** 12/23/2018  
**PAGE NO:** 4



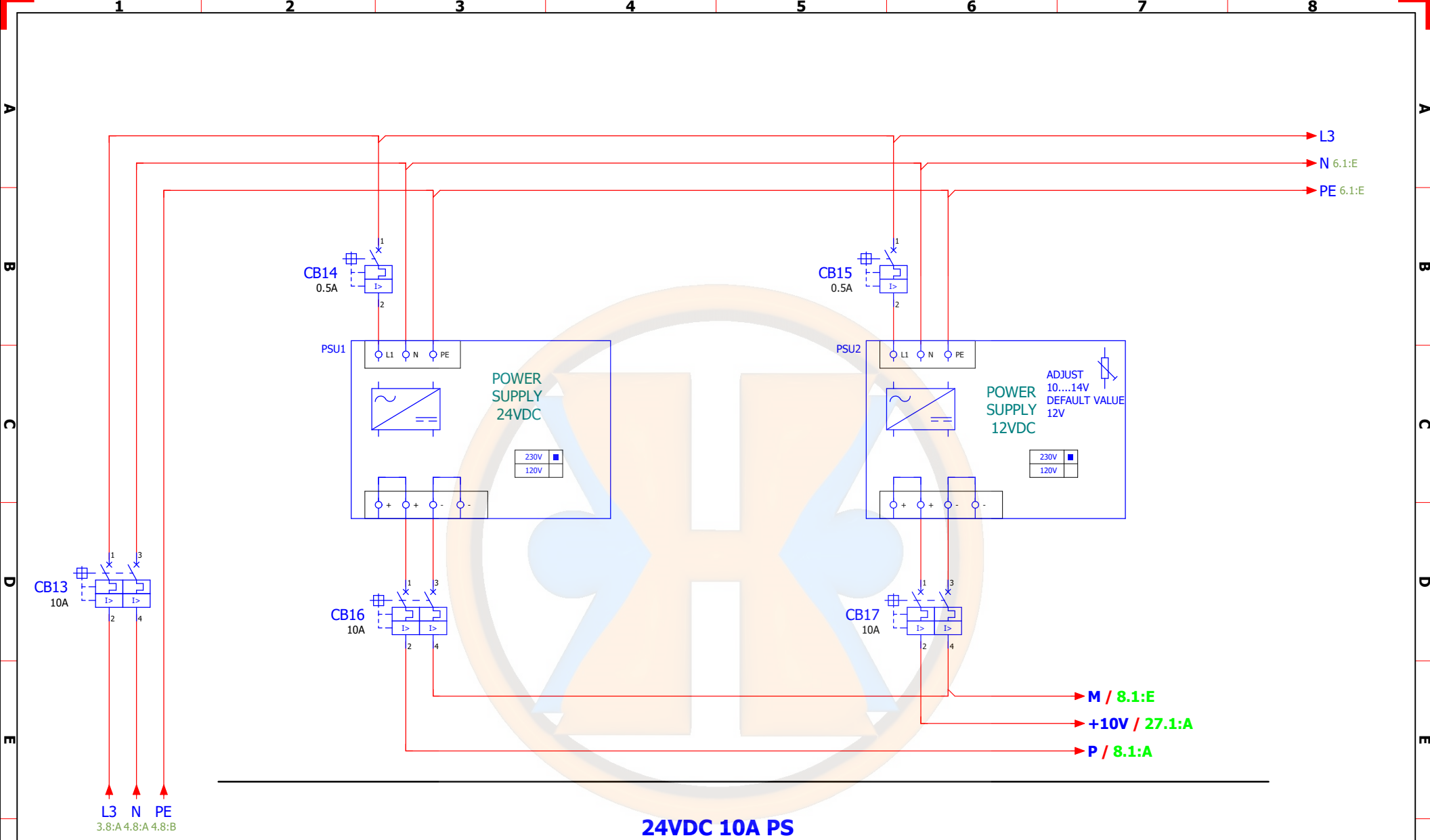

**24VDC 10A PS**

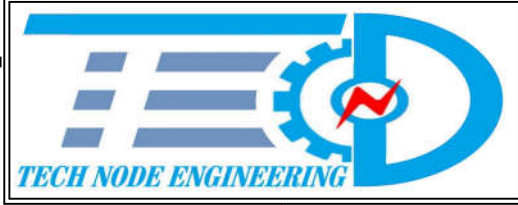

**PROJECT DESCRIPTION:**

**CREATOR:** HAYL KHADHAMI

**CHECKER:** MAJED AL-BORAEI

**APPROVER:** TECHNOD

**COMMISSION:** TECHNOD ENGINEERING



**DATE:** 12/23/2018

**PAGE NO:** 5

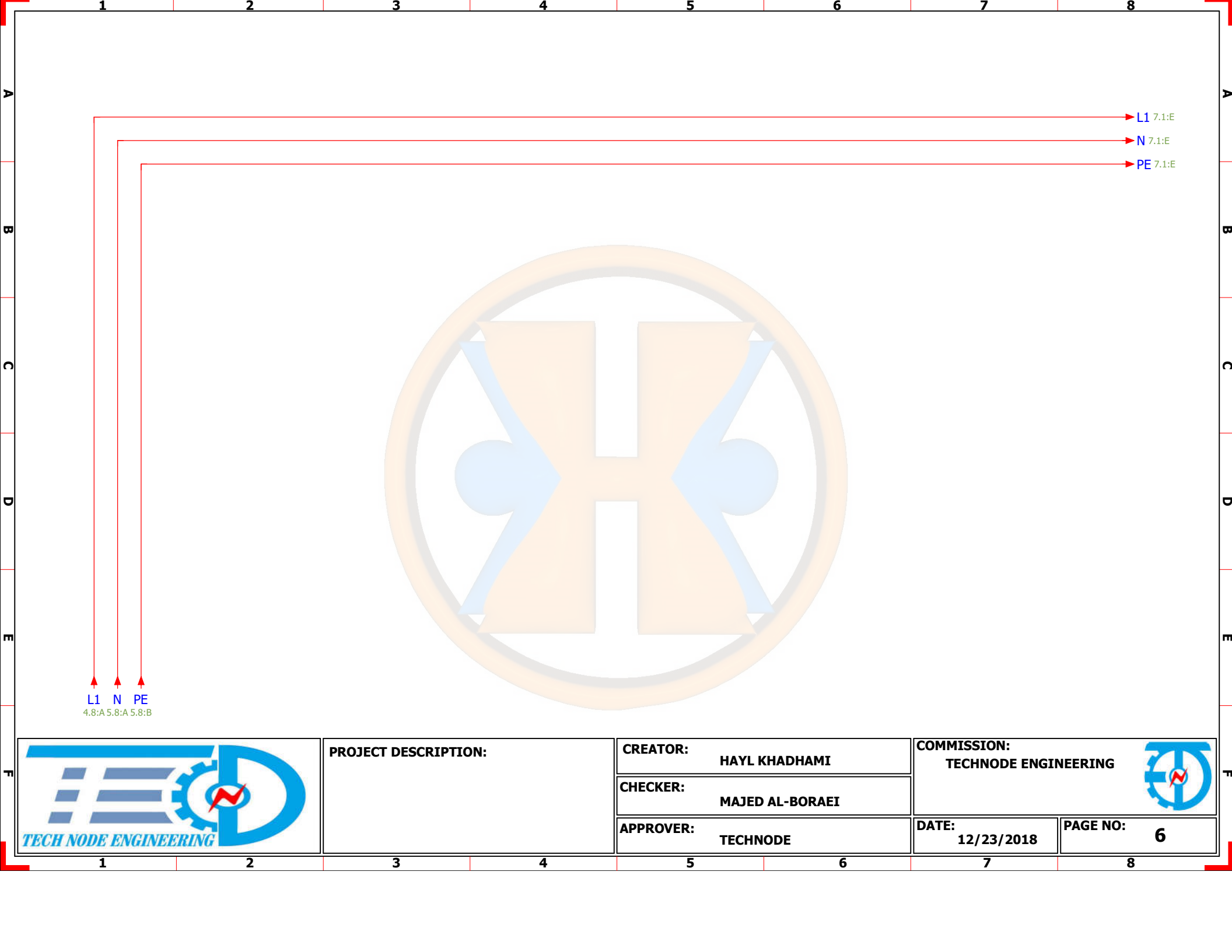

L1 7.1:E

N 7.1:E

PE 7.1:E

L1 N PE  
4.8:A 5.8:A 5.8:B

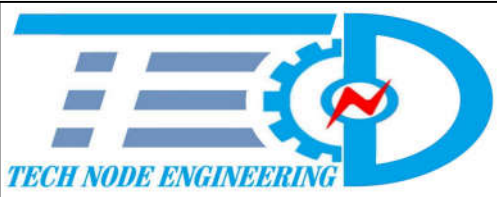

**PROJECT DESCRIPTION:**

**CREATOR:** HAYL KHADHAMI

**CHECKER:** MAJED AL-BORAEI

**APPROVER:** TECHNODE

**COMMISSION:** TECHNODE ENGINEERING



**DATE:** 12/23/2018

**PAGE NO:** 6

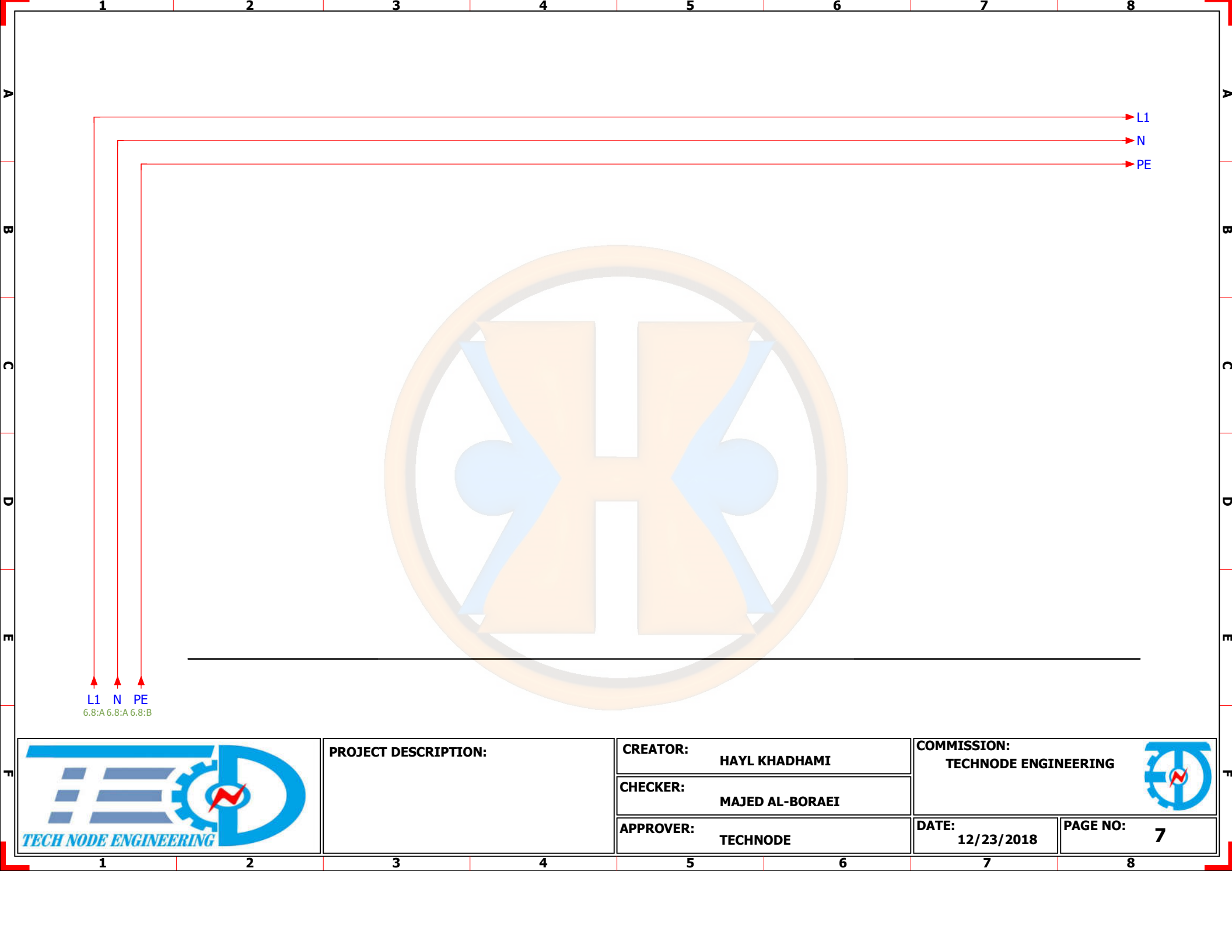

L1 N PE  
6.8:A 6.8:A 6.8:B

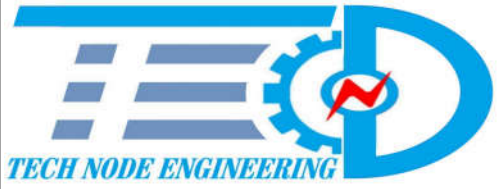

**PROJECT DESCRIPTION:**

**CREATOR:** HAYL KHADHAMI

**CHECKER:** MAJED AL-BORAEI

**APPROVER:** TECHNODE

**COMMISSION:** TECHNODE ENGINEERING



**DATE:** 12/23/2018

**PAGE NO:** 7

P / 5.7:E

P / 10.1:A

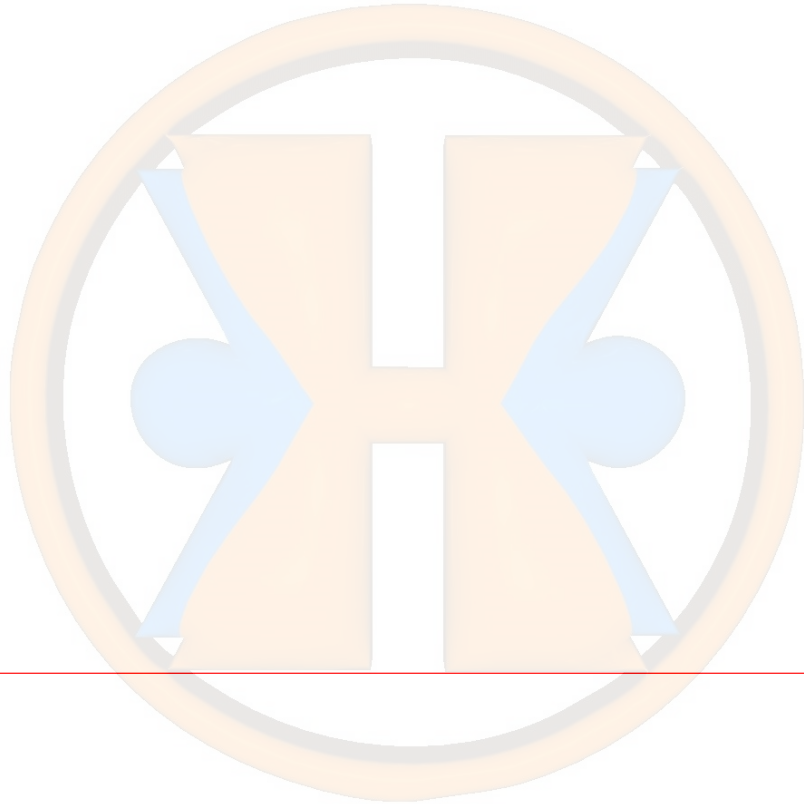

M / 5.7:E

M / 9.1:E

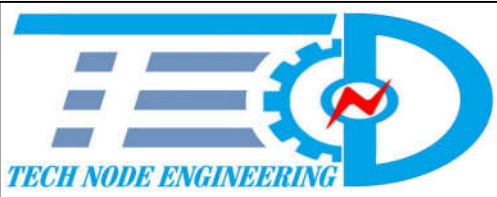

**PROJECT DESCRIPTION:**

**CREATOR:** HAYL KHADHAMI  
**CHECKER:** MAJED AL-BORAEI  
**APPROVER:** TECHNODE

**COMMISSION:** TECHNODE ENGINEERING   
**DATE:** 12/23/2018  
**PAGE NO:** 8



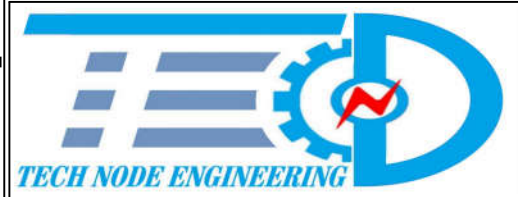
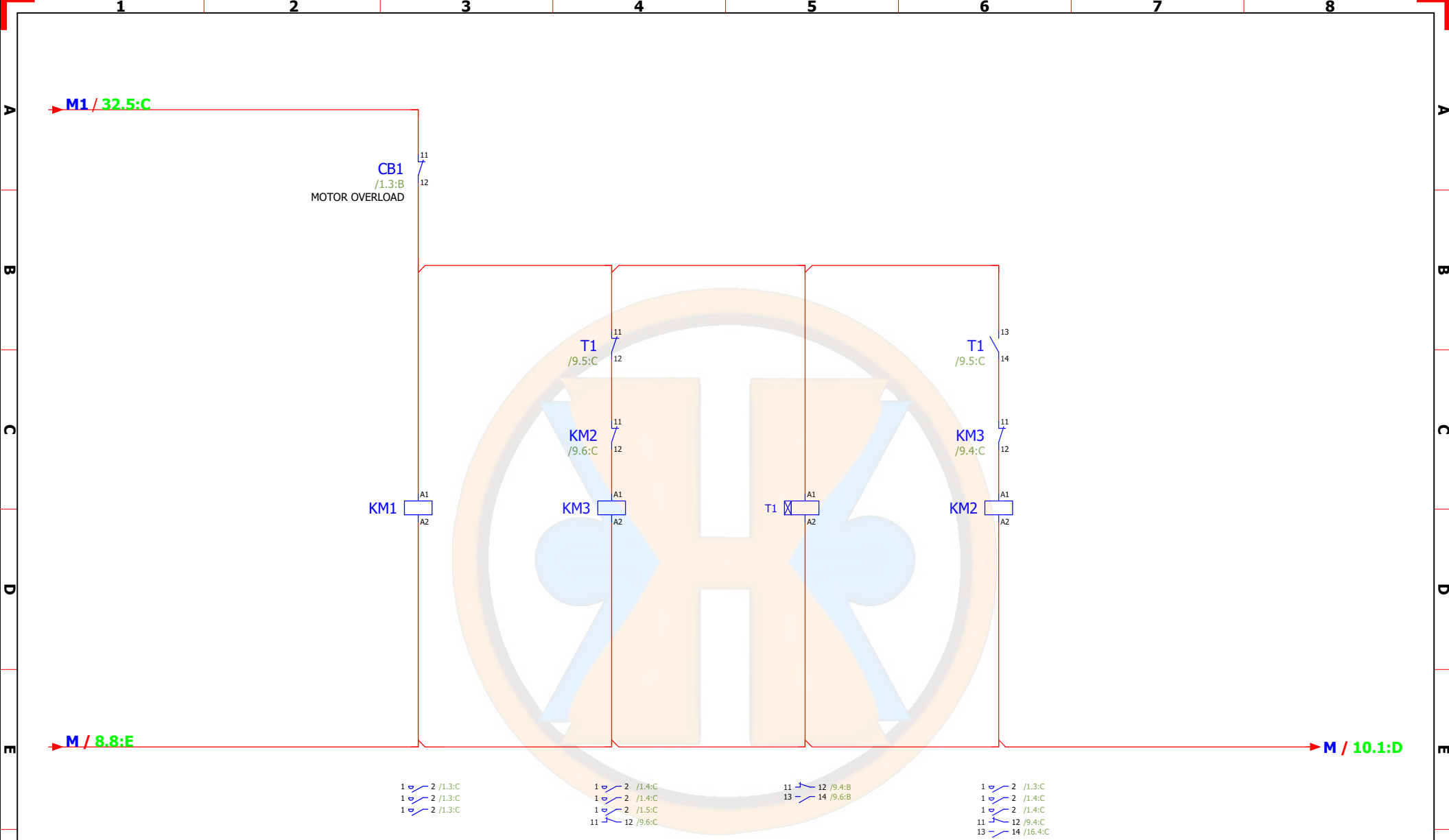

**PROJECT DESCRIPTION:**

**CREATOR:** HAYL KHADHAMI

**CHECKER:** MAJED AL-BORAEI

**APPROVER:** TECHNOD

**COMMISSION:** TECHNOD ENGINEERING

**DATE:** 12/23/2018

**PAGE NO:** 9



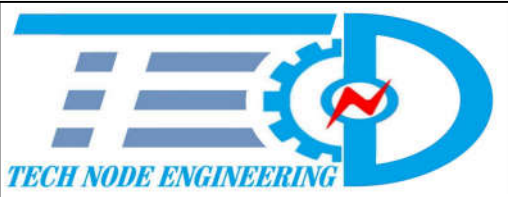
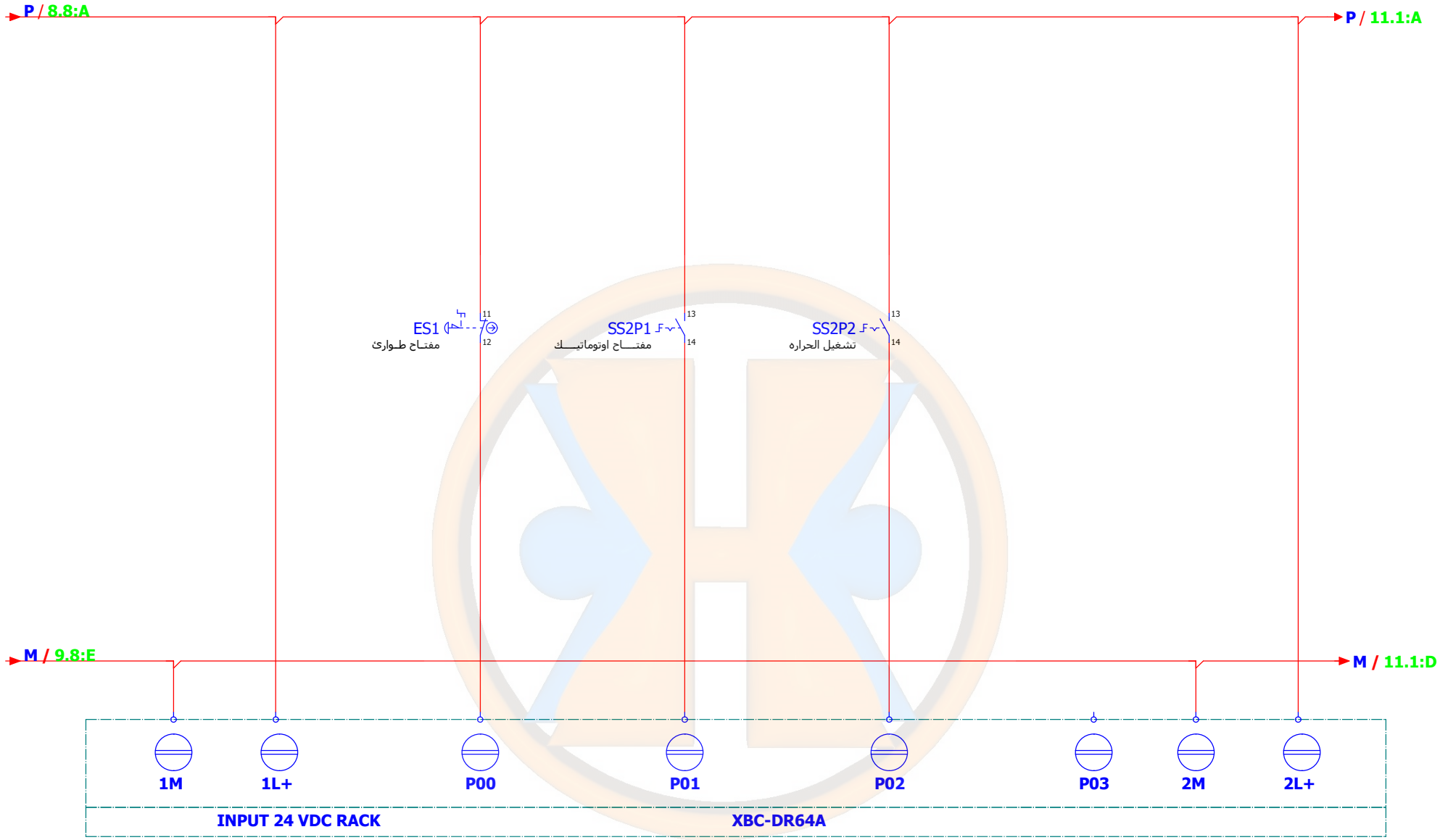

**PROJECT DESCRIPTION:**

**CREATOR:** HAYL KHADHAMI  
**CHECKER:** MAJED AL-BORAEI  
**APPROVER:** TECHNOD

**COMMISSION:** TECHNOD ENGINEERING  
**DATE:** 12/23/2018  
**PAGE NO:** 10





P/ 10.8:A

P/ 12.1:A

M

.1:D

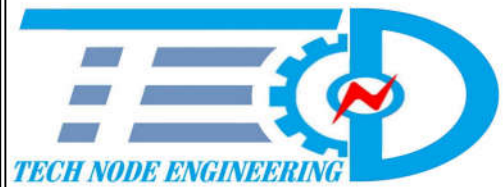

PROJECT DESCRIPTION:

CREATOR: HAYL KHADHAMI  
CHECKER: MAJED AL-BORAEI  
APPROVER: TECHNODE

COMMISSION: TECHNODE ENGINEERING  
DATE: 12/23/2018  
PAGE NO: 11



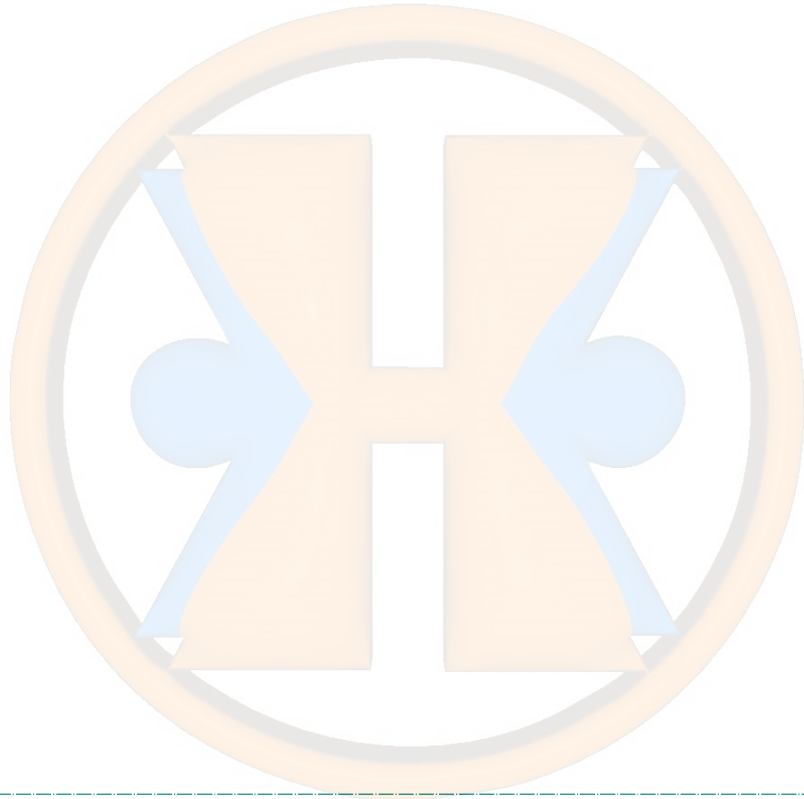

P / 11.8:A

P / 13.1:A

M / 11

:D

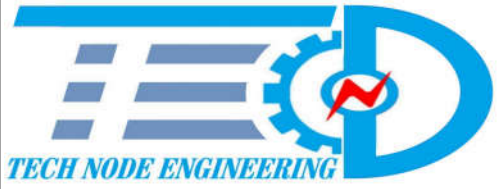

PROJECT DESCRIPTION:

CREATOR: HAYL KHADHAMI  
CHECKER: MAJED AL-BORAEI  
APPROVER: TECHNODE

COMMISSION: TECHNODE ENGINEERING  
DATE: 12/23/2018  
PAGE NO: 12



1 2 3 4 5 6 7 8

P/ 12.8:A P/ 14.1:A

A  
B  
C  
D  
E  
F

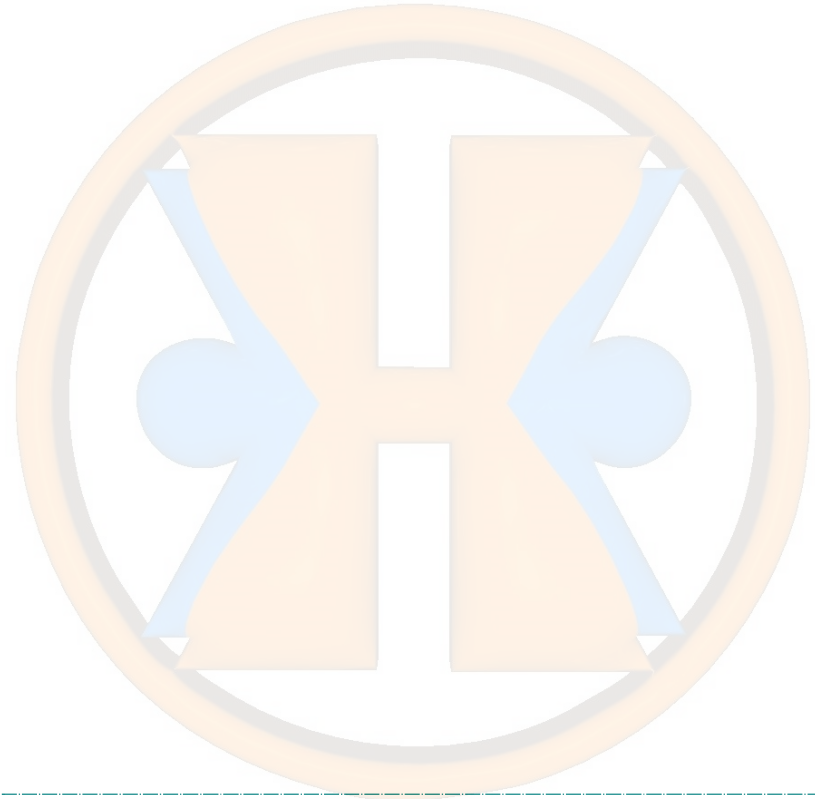

M/ 4.1:D

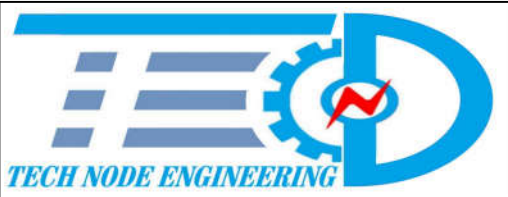

PROJECT DESCRIPTION:

CREATOR: HAYL KHADHAMI  
CHECKER: MAJED AL-BORAEI  
APPROVER: TECHNODE

COMMISSION: TECHNODE ENGINEERING  
DATE: 12/23/2018  
PAGE NO: 13



1 2 3 4 5 6 7 8

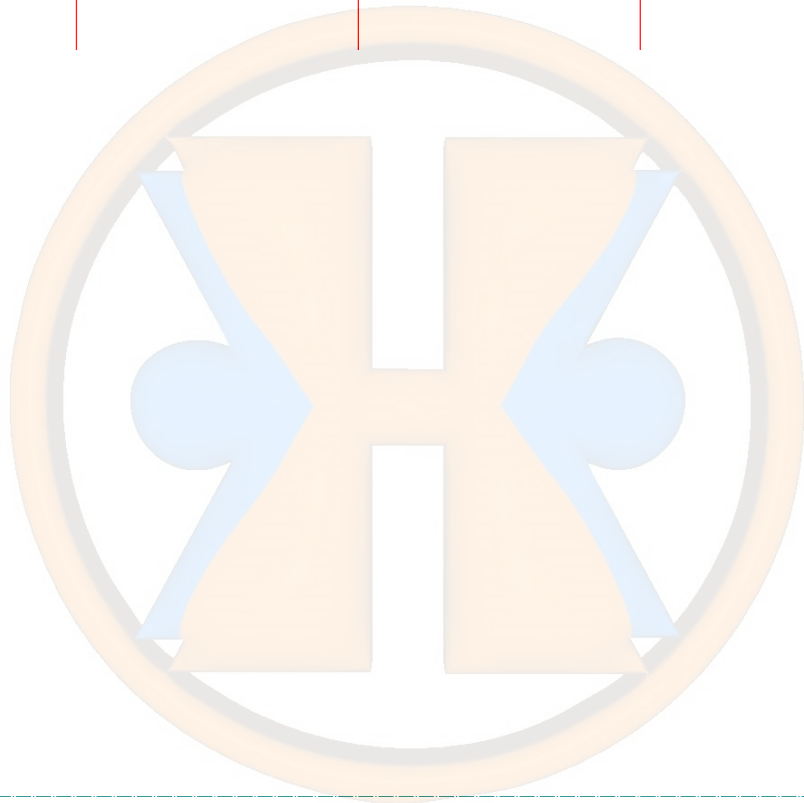

P / 13.8:A

P / 15.1:A

M / 13.8:D

5.1:D



PROJECT DESCRIPTION:

CREATOR: HAYL KHADHAMI  
CHECKER: MAJED AL-BORAEI  
APPROVER: TECHNODE

COMMISSION: TECHNODE ENGINEERING  
DATE: 12/23/2018  
PAGE NO: 14



1 2 3 4 5 6 7 8

P / 14.8:A P / 16.1:A

A  
B  
C  
D  
E  
F



M / 14.8:D

6.1:D

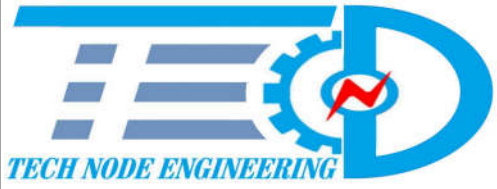
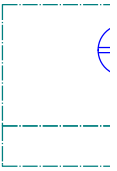

PROJECT DESCRIPTION:

CREATOR:	HAYL KHADHAMI
CHECKER:	MAJED AL-BORAEI
APPROVER:	TECHNODE

COMMISSION:		
TECHNODE ENGINEERING		
DATE:	12/23/2018	PAGE NO: 15

1 2 3 4 5 6 7 8

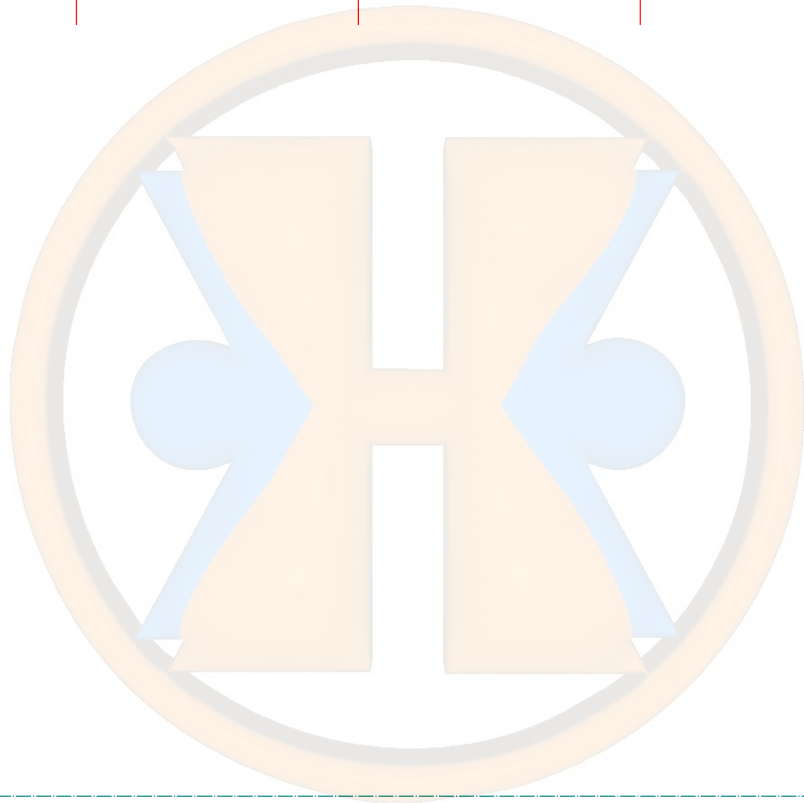

P / 15.8:A

P / 17.1:A

M / 15.8:D

M / 17.1:D

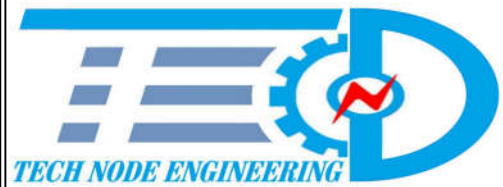
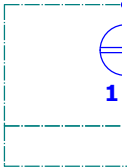

PROJECT DESCRIPTION:

CREATOR: HAYL KHADHAMI  
CHECKER: MAJED AL-BORAEI  
APPROVER: TECHNODE

COMMISSION: TECHNODE ENGINEERING  
DATE: 12/23/2018  
PAGE NO: 16







P / 16.8:A

P / 18.1:A

M / 16.8:D

M / 18.1:E



PROJECT DESCRIPTION:

CREATOR: HAYL KHADHAMI

COMMISSION: TECHNOD ENGINEERING



CHECKER: MAJED AL-BORAEI

APPROVER: TECHNOD

DATE: 12/23/2018

PAGE NO: 17

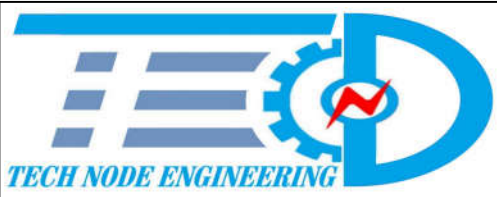
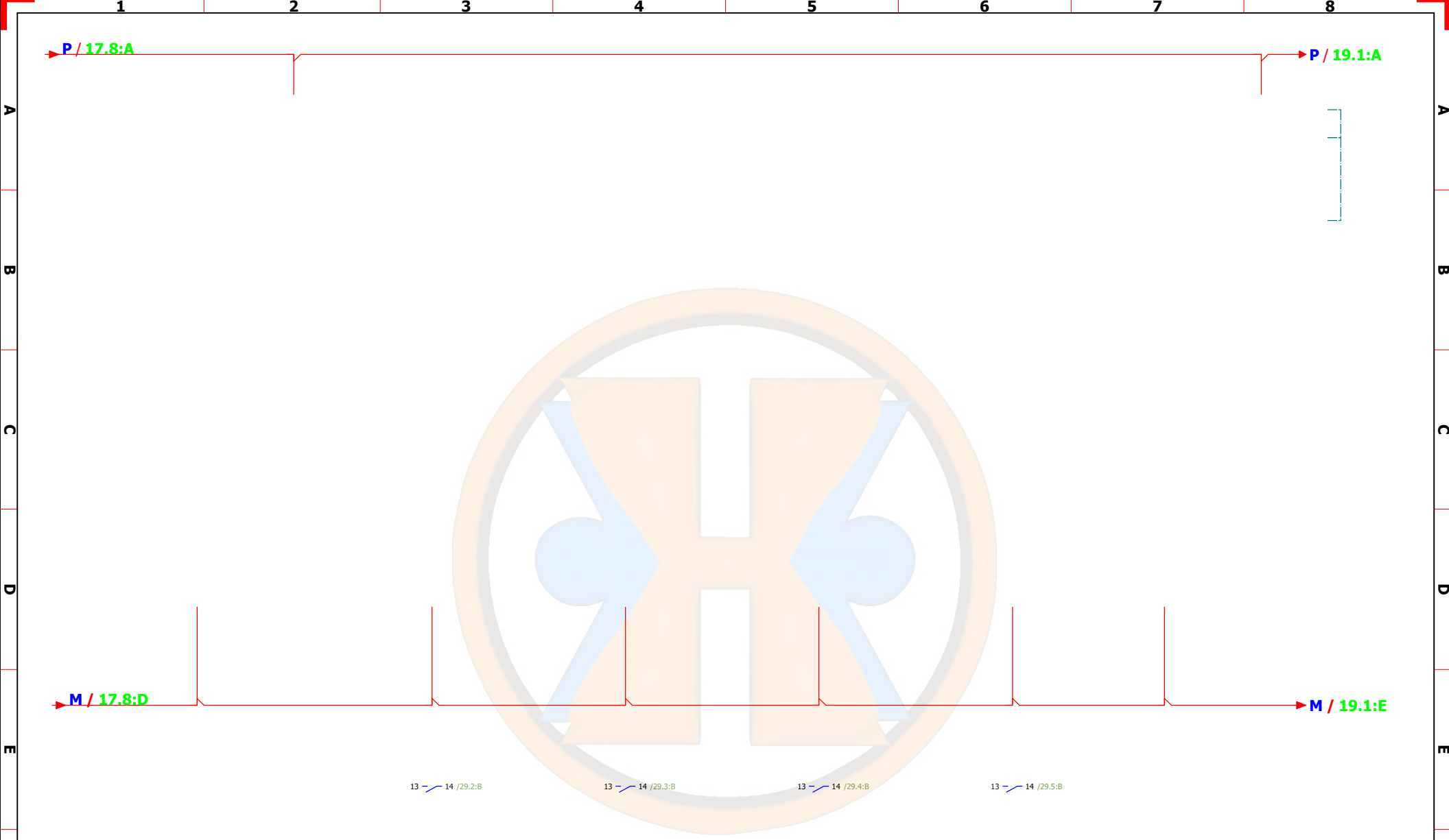

**PROJECT DESCRIPTION:**

**CREATOR:** HAYL KHADHAMI  
**CHECKER:** MAJED AL-BORAEI  
**APPROVER:** TECHNODE

**COMMISSION:** TECHNODE ENGINEERING   
**DATE:** 12/23/2018  
**PAGE NO:** 18

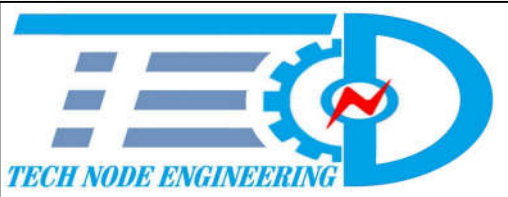
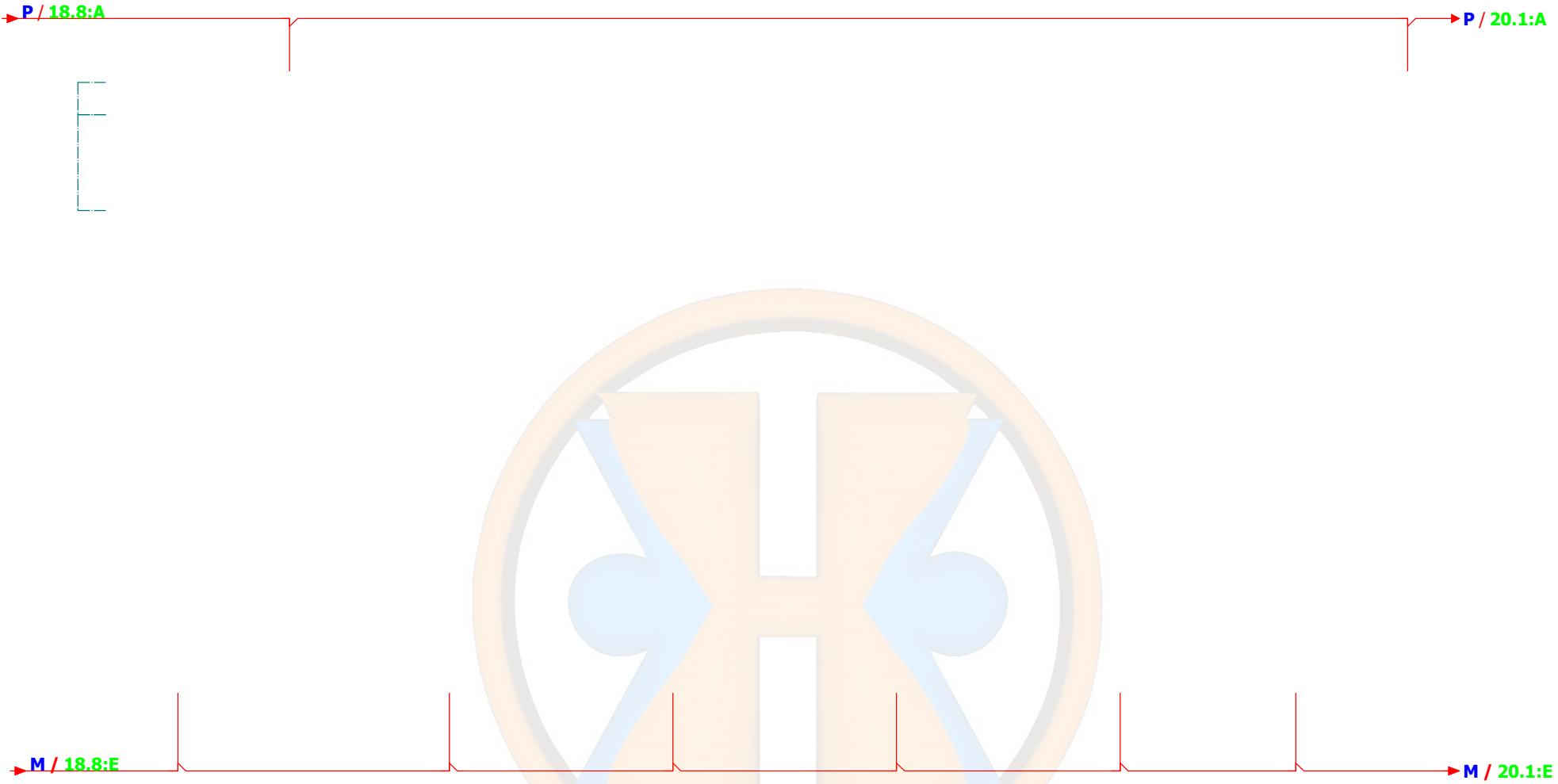

**PROJECT DESCRIPTION:**

**CREATOR:** HAYL KHADHAMI

**CHECKER:** MAJED AL-BORAEI

**APPROVER:** TECHNODE

**COMMISSION:** TECHNODE ENGINEERING



**DATE:** 12/23/2018

**PAGE NO:** 19

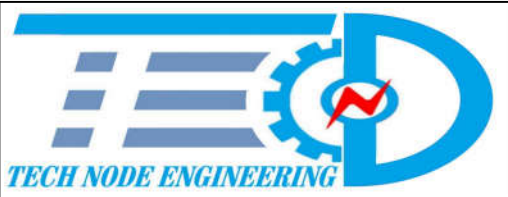
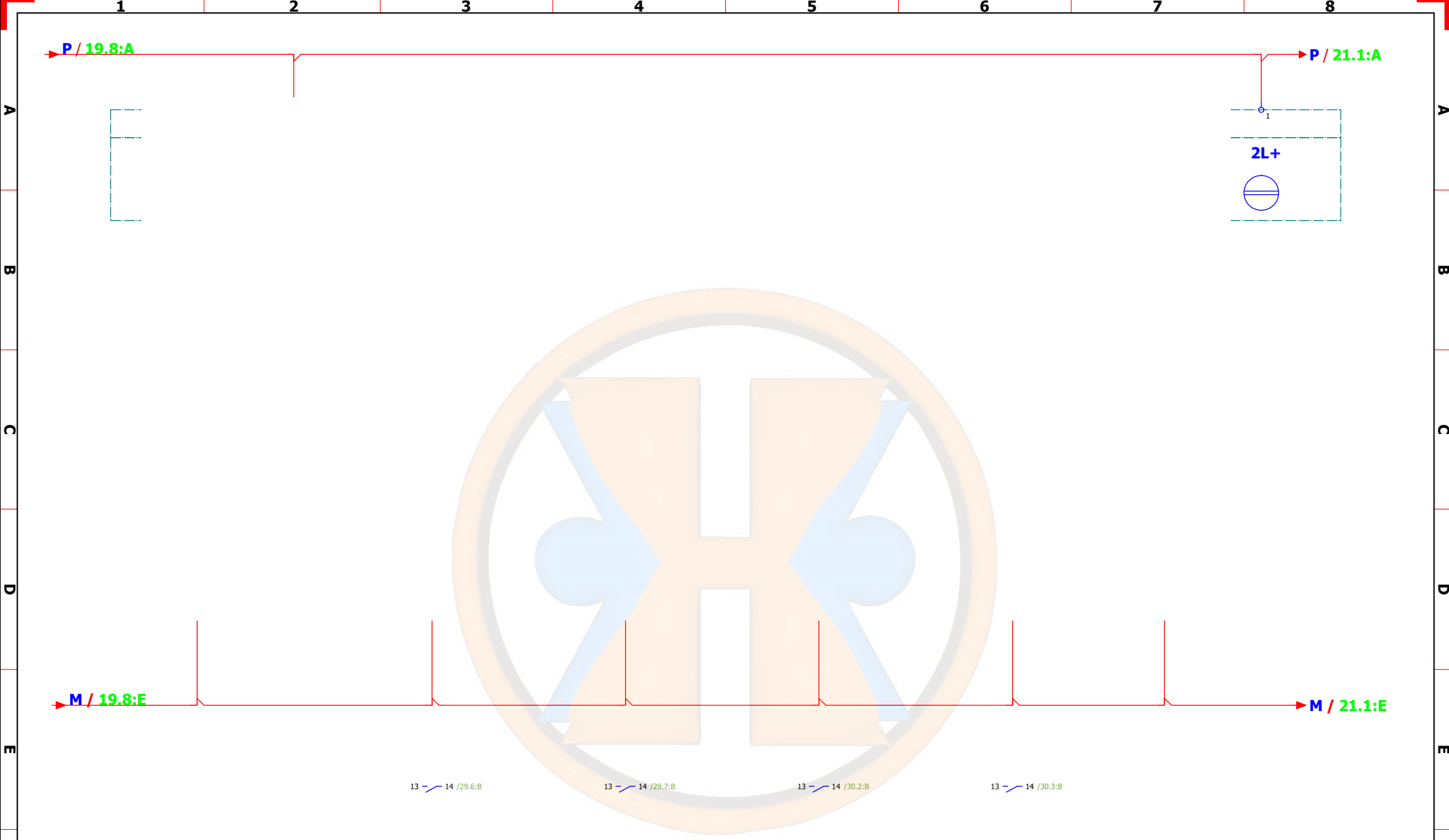

**PROJECT DESCRIPTION:**

**CREATOR:** HAYL KHADHAMI

**CHECKER:** MAJED AL-BORAEI

**APPROVER:** TECHNODE

**COMMISSION:** TECHNODE ENGINEERING



**DATE:** 12/23/2018

**PAGE NO:** 20

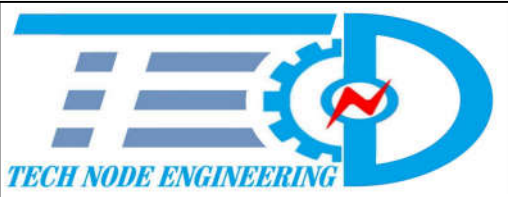
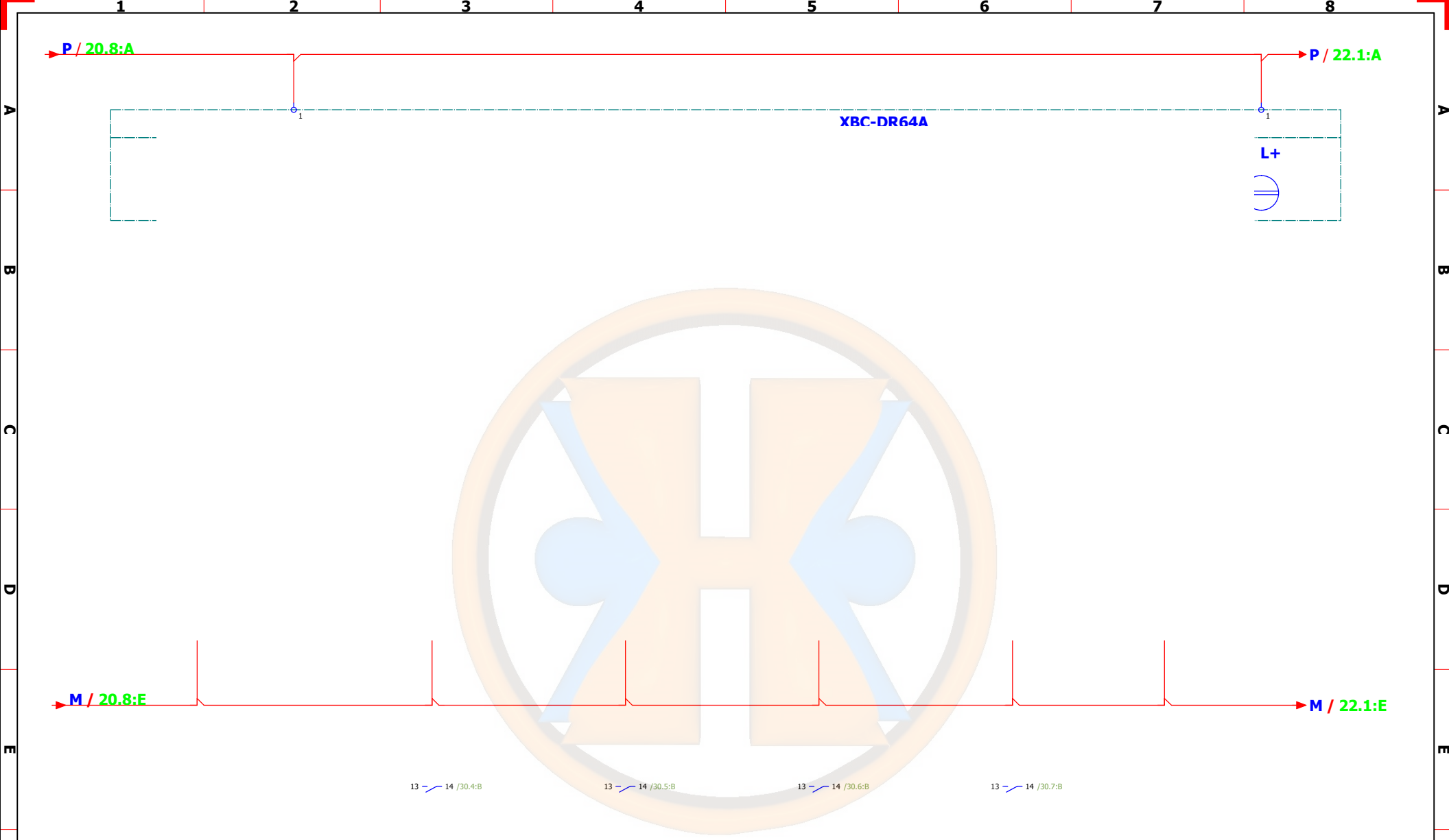

**PROJECT DESCRIPTION:**

**CREATOR:** HAYL KHADHAMI  
**CHECKER:** MAJED AL-BORAEI  
**APPROVER:** TECHNODE

**COMMISSION:** TECHNODE ENGINEERING

**DATE:** 12/23/2018      **PAGE NO:** 21



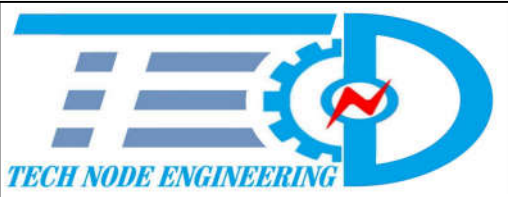
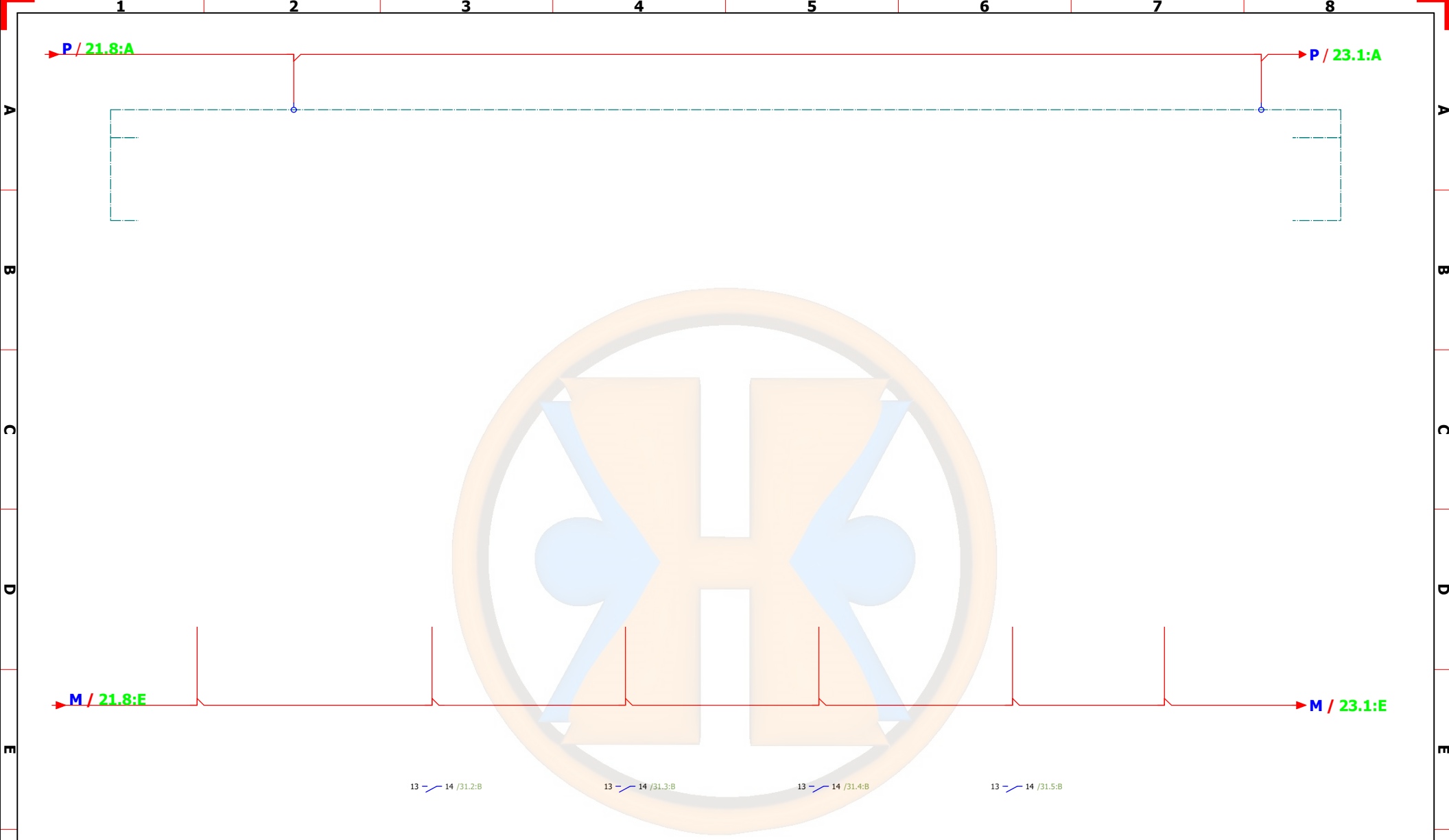

**PROJECT DESCRIPTION:**

**CREATOR:** HAYL KHADHAMI

**CHECKER:** MAJED AL-BORAEI

**APPROVER:** TECHNODE

**COMMISSION:** TECHNODE ENGINEERING



**DATE:** 12/23/2018

**PAGE NO:** 22

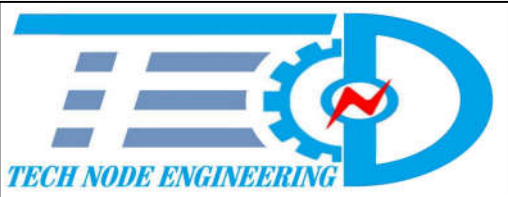
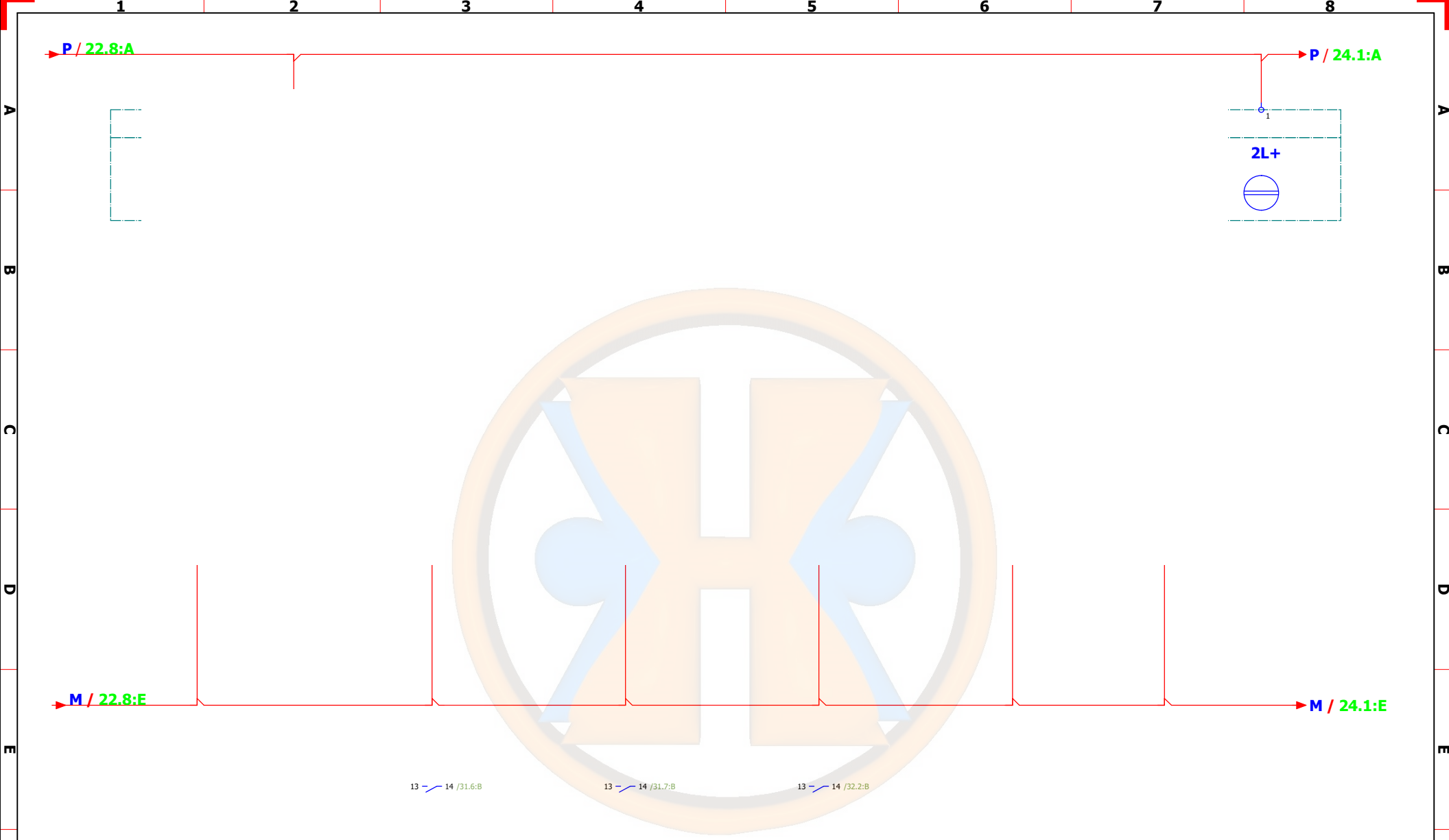

**PROJECT DESCRIPTION:**

**CREATOR:** HAYL KHADHAMI  
**CHECKER:** MAJED AL-BORAEI  
**APPROVER:** TECHNODE

**COMMISSION:** TECHNODE ENGINEERING

**DATE:** 12/23/2018      **PAGE NO:** 23



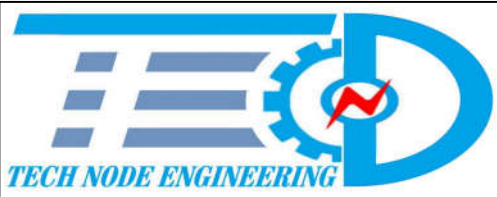
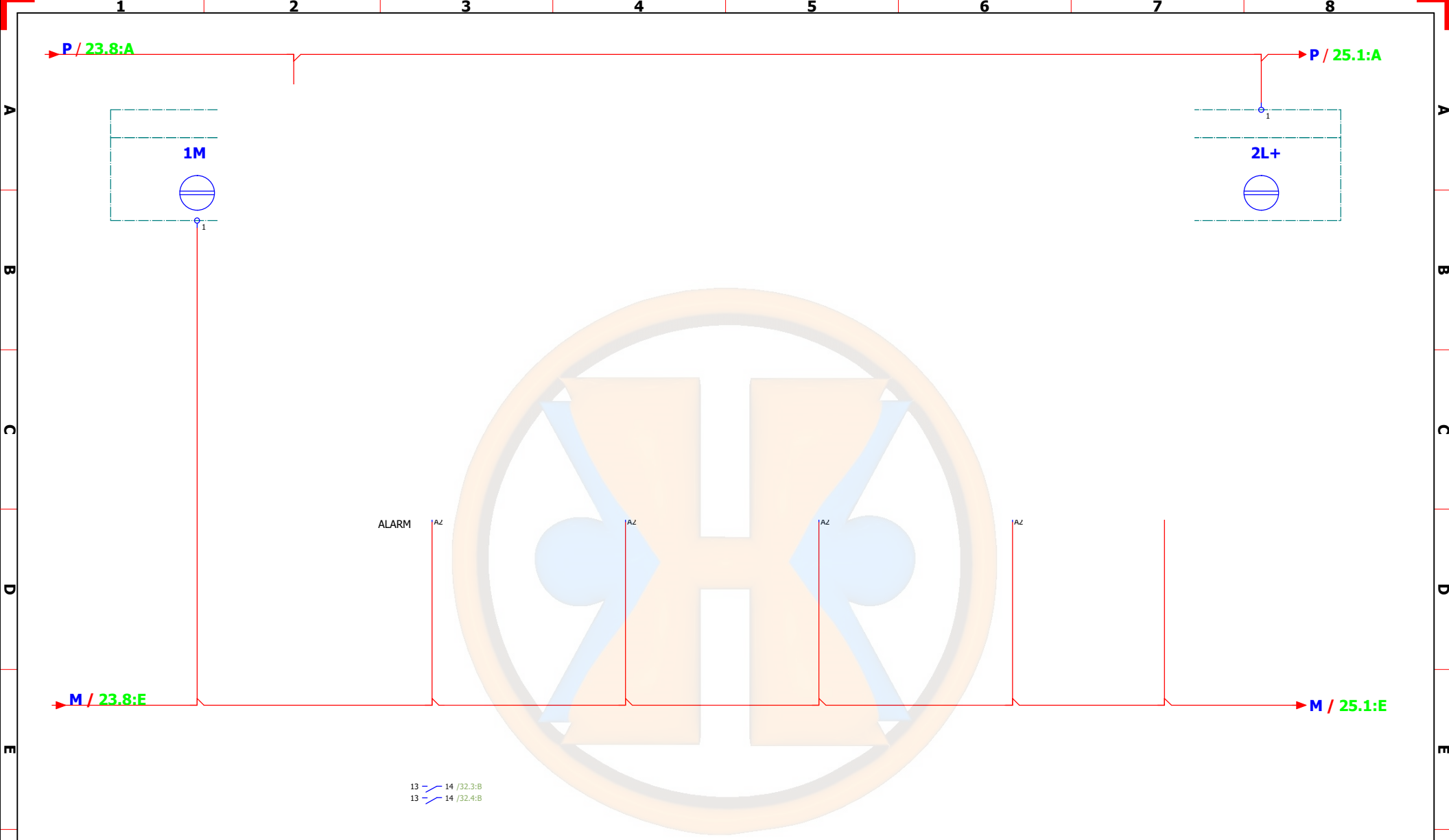

**PROJECT DESCRIPTION:**

**CREATOR:** HAYL KHADHAMI  
**CHECKER:** MAJED AL-BORAEI  
**APPROVER:** TECHNOD

**COMMISSION:** TECHNOD ENGINEERING   
**DATE:** 12/23/2018  
**PAGE NO:** 24



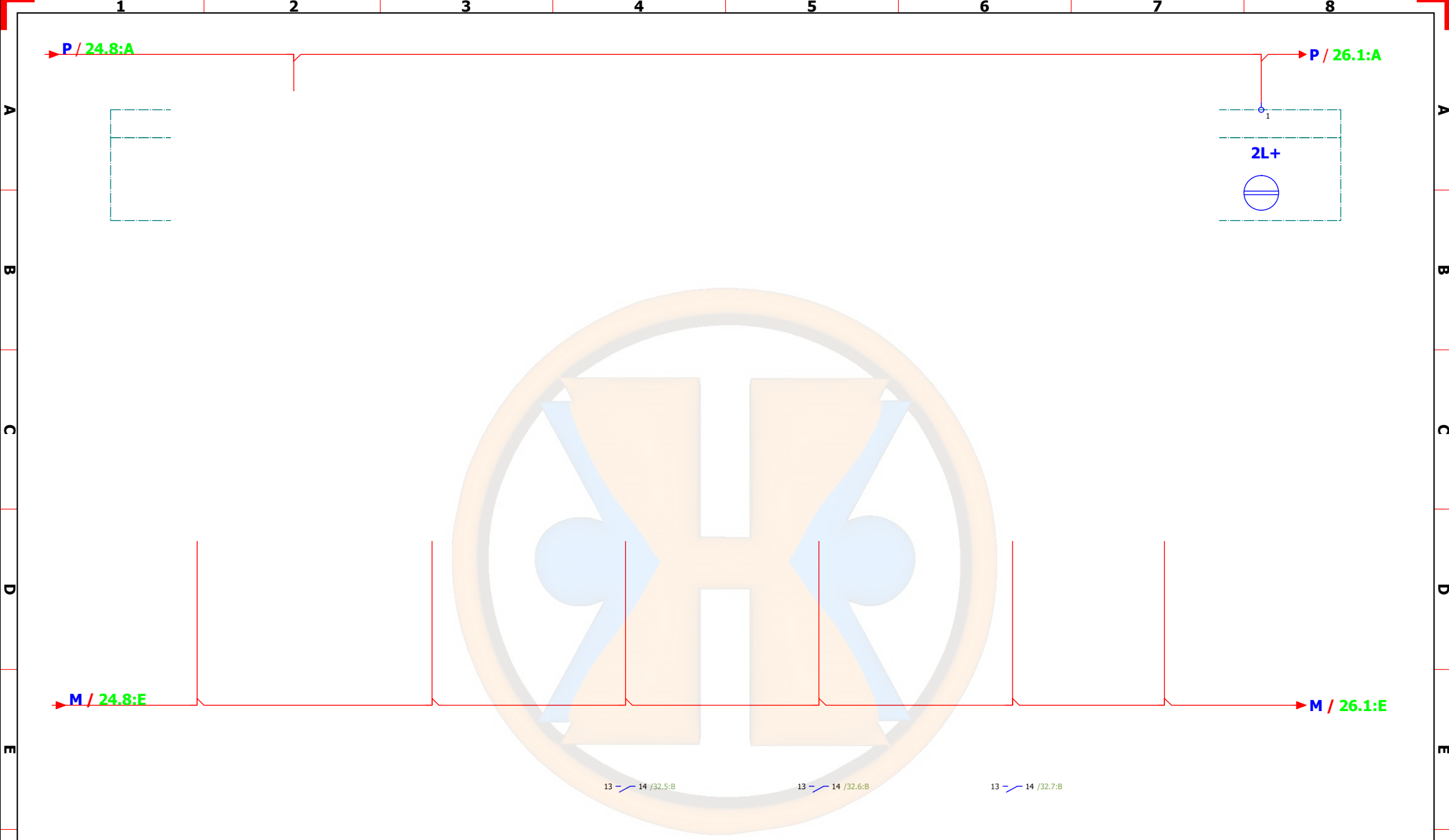

13 - 14 /32.5:B

13 - 14 /32.6:B

13 - 14 /32.7:B

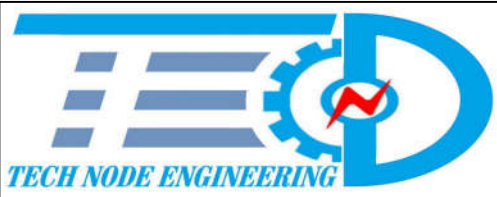

**PROJECT DESCRIPTION:**

**CREATOR:** HAYL KHADHAMI

**CHECKER:** MAJED AL-BORAEI

**APPROVER:** TECHNODE

**COMMISSION:** TECHNODE ENGINEERING



**DATE:** 12/23/2018

**PAGE NO:** 25

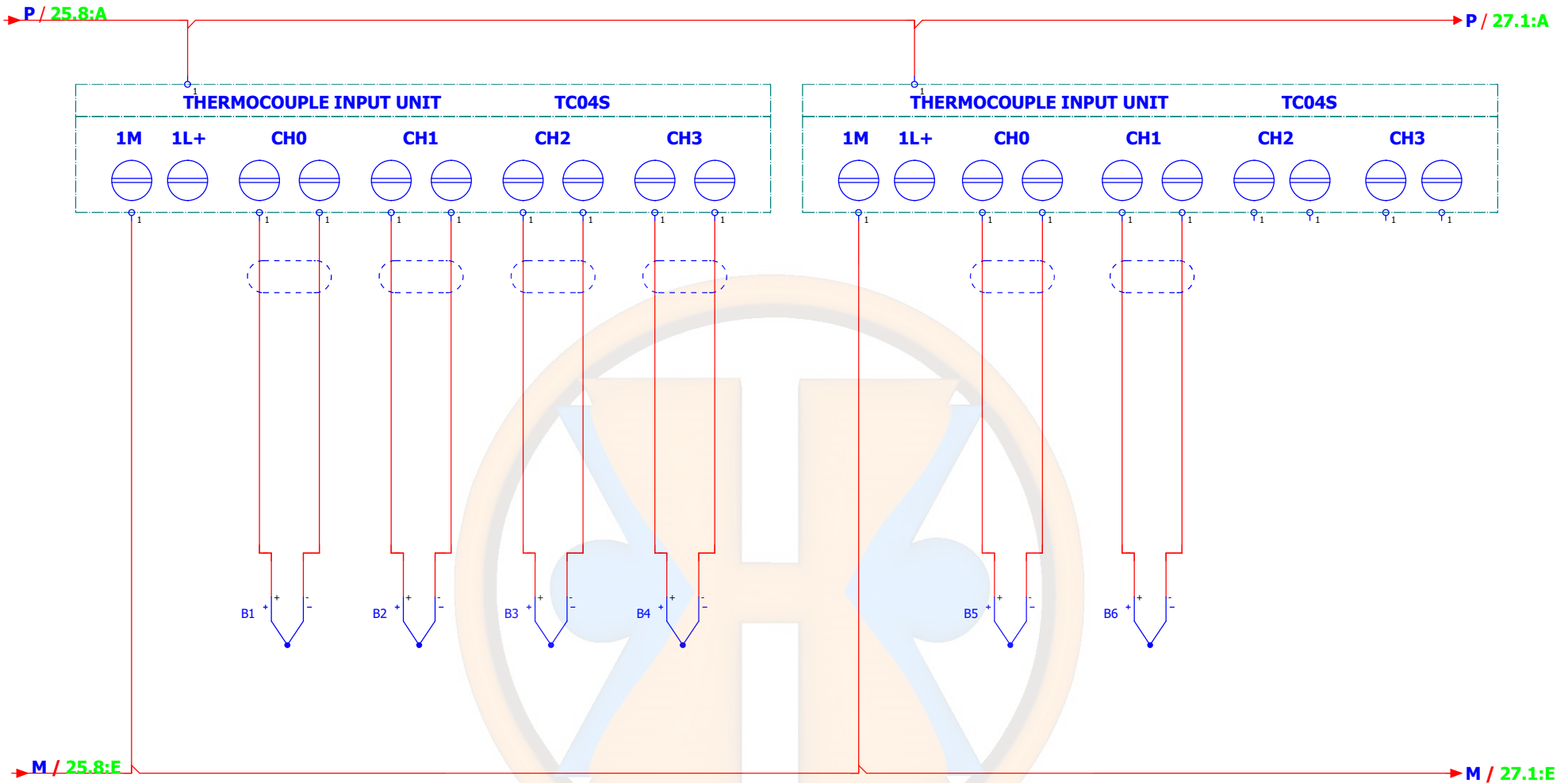

## TEMPERATURE SENSORS

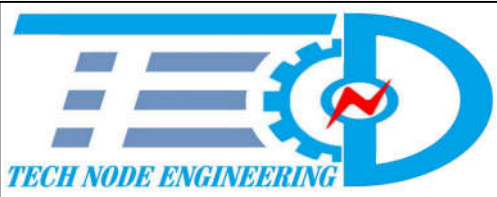

**PROJECT DESCRIPTION:**

**CREATOR:** HAYL KHADHAMI  
**CHECKER:** MAJED AL-BORAEI  
**APPROVER:** TECHNOD

**COMMISSION:** TECHNOD ENGINEERING

**DATE:** 12/23/2018      **PAGE NO:** 26



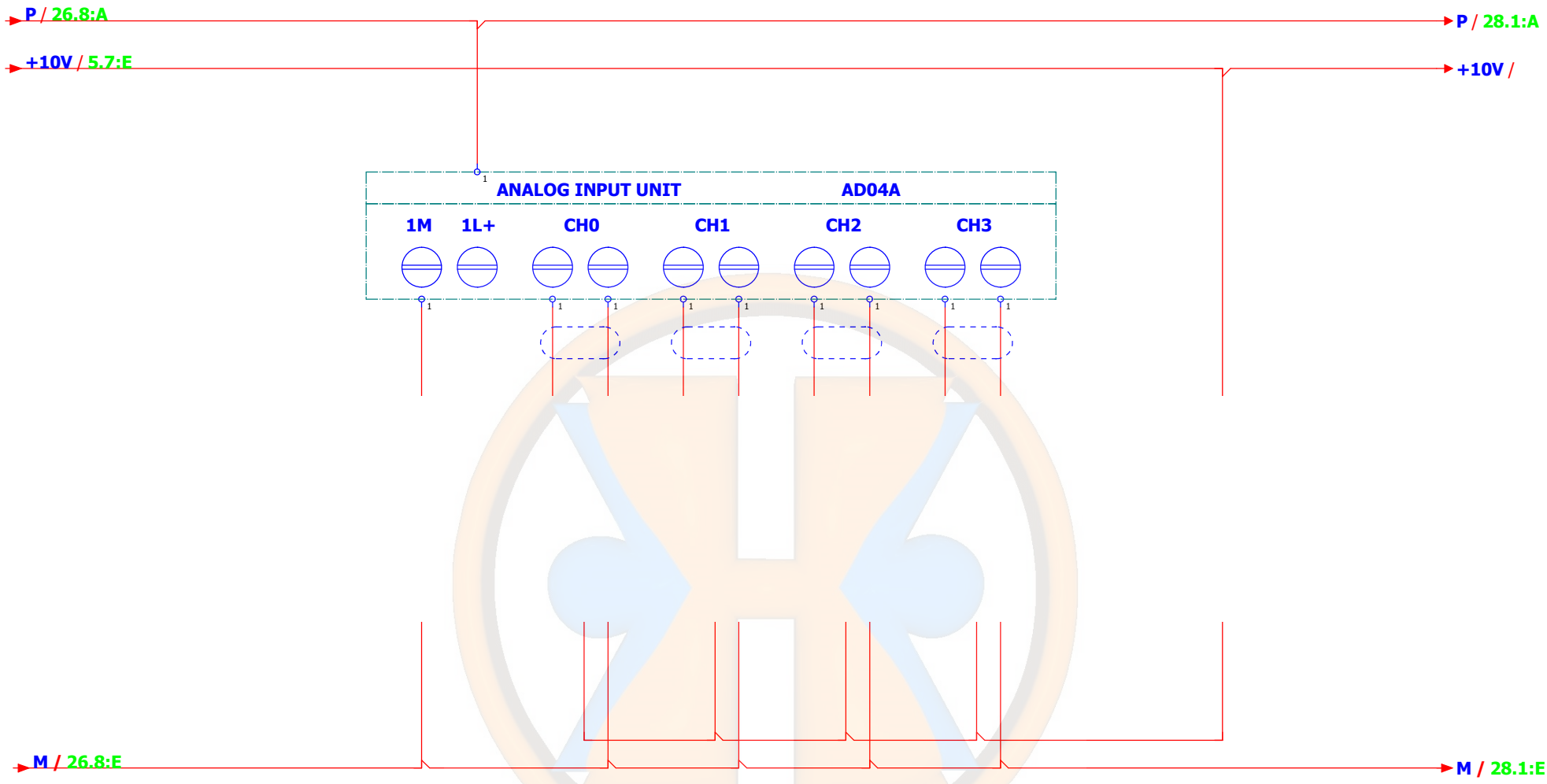

## POSITION SENSORS

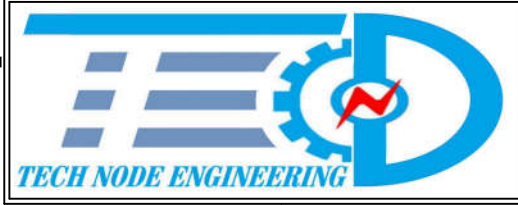

**PROJECT DESCRIPTION:**

**CREATOR:** HAYL KHADHAMI

**CHECKER:** MAJED AL-BORAEI

**APPROVER:** TECHNOD

**COMMISSION:** TECHNOD ENGINEERING



**DATE:** 12/23/2018

**PAGE NO:** 27

P / 27.8:A

P / 29.1:A

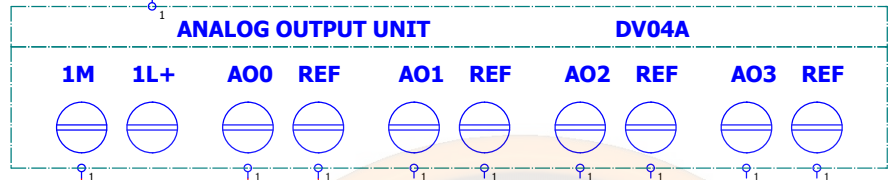

M / 27.8:E

M / 29.1:E

### POSITION SENSORS

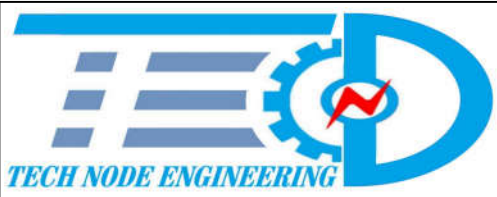

PROJECT DESCRIPTION:

CREATOR:

HAYL KHADHAMI

COMMISSION:

TECHNODE ENGINEERING



CHECKER:

MAJED AL-BORAEI

APPROVER:

TECHNODE

DATE:

12/23/2018

PAGE NO:

28

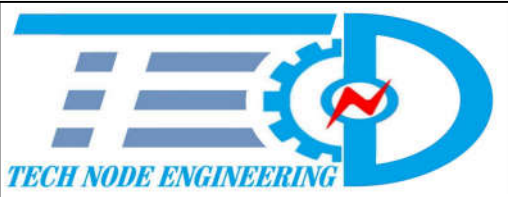
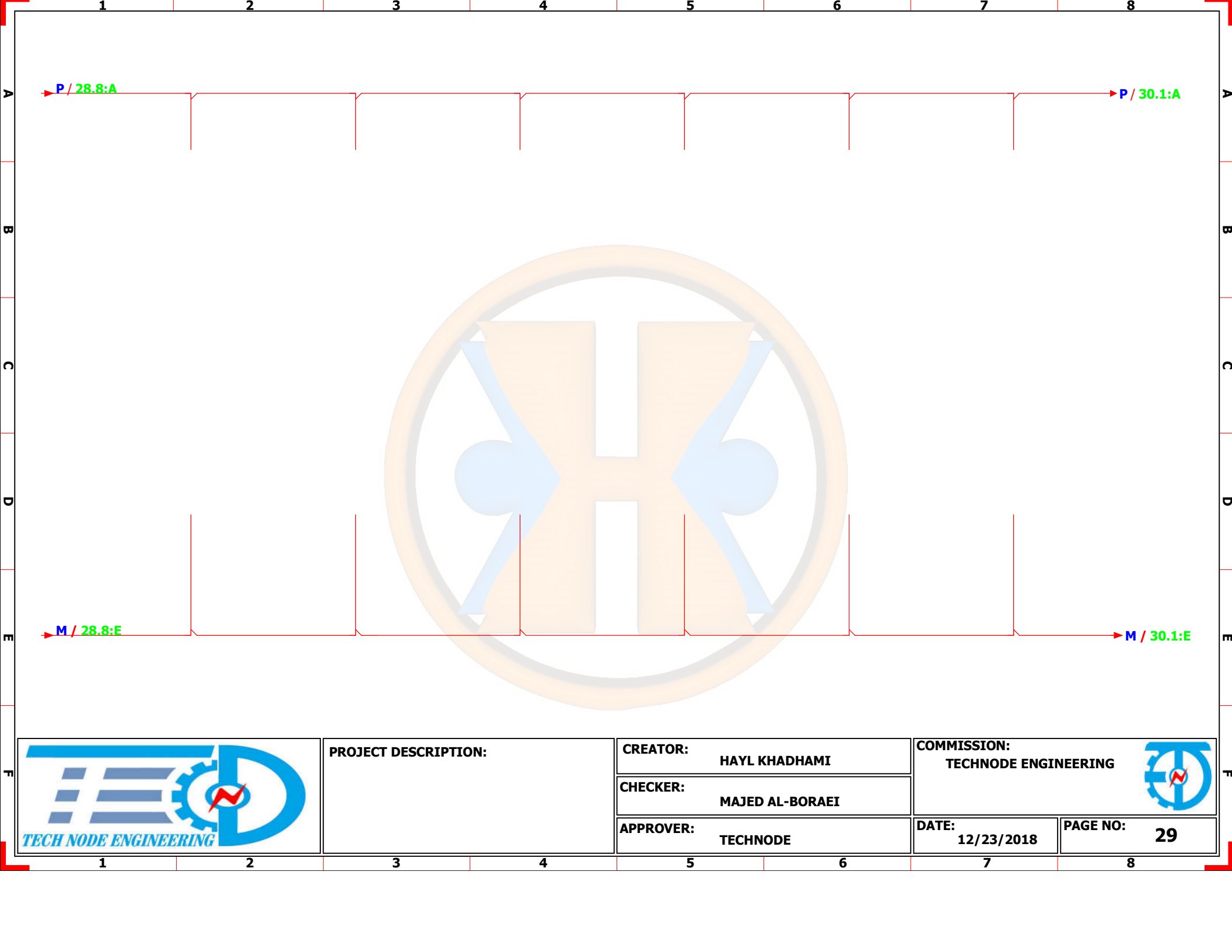

**PROJECT DESCRIPTION:**

**CREATOR:** HAYL KHADHAMI  
**CHECKER:** MAJED AL-BORAEI  
**APPROVER:** TECHNODE

**COMMISSION:** TECHNODE ENGINEERING   
**DATE:** 12/23/2018  
**PAGE NO:** 29

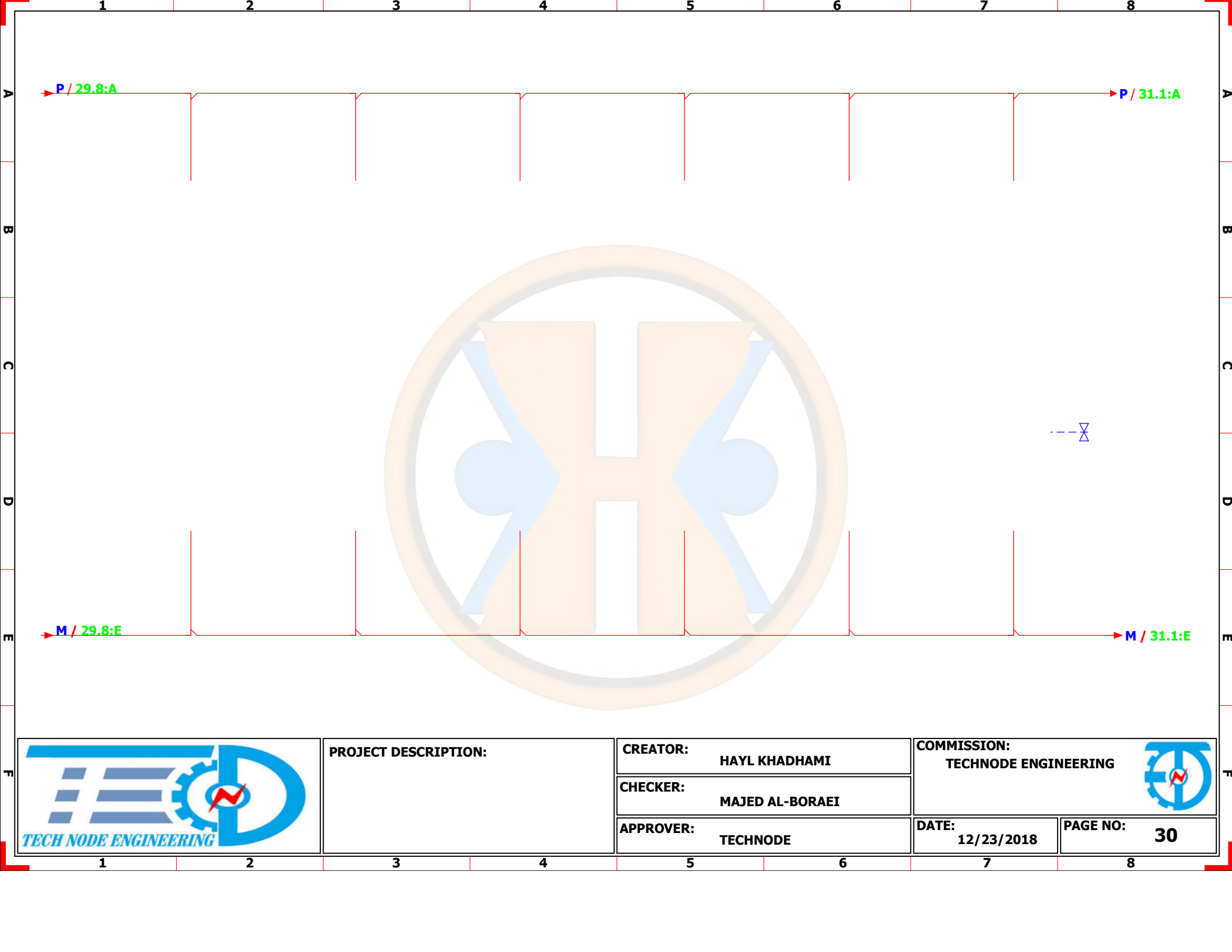

**PROJECT DESCRIPTION:**

**CREATOR:** HAYL KHADHAMI  
**CHECKER:** MAJED AL-BORAEI  
**APPROVER:** TECHNODE

**COMMISSION:** TECHNODE ENGINEERING  
**DATE:** 12/23/2018  
**PAGE NO:** 30



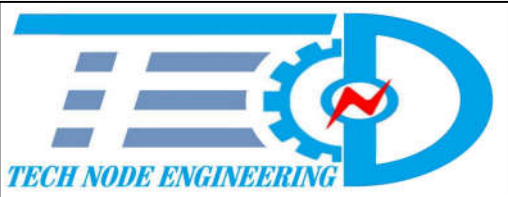
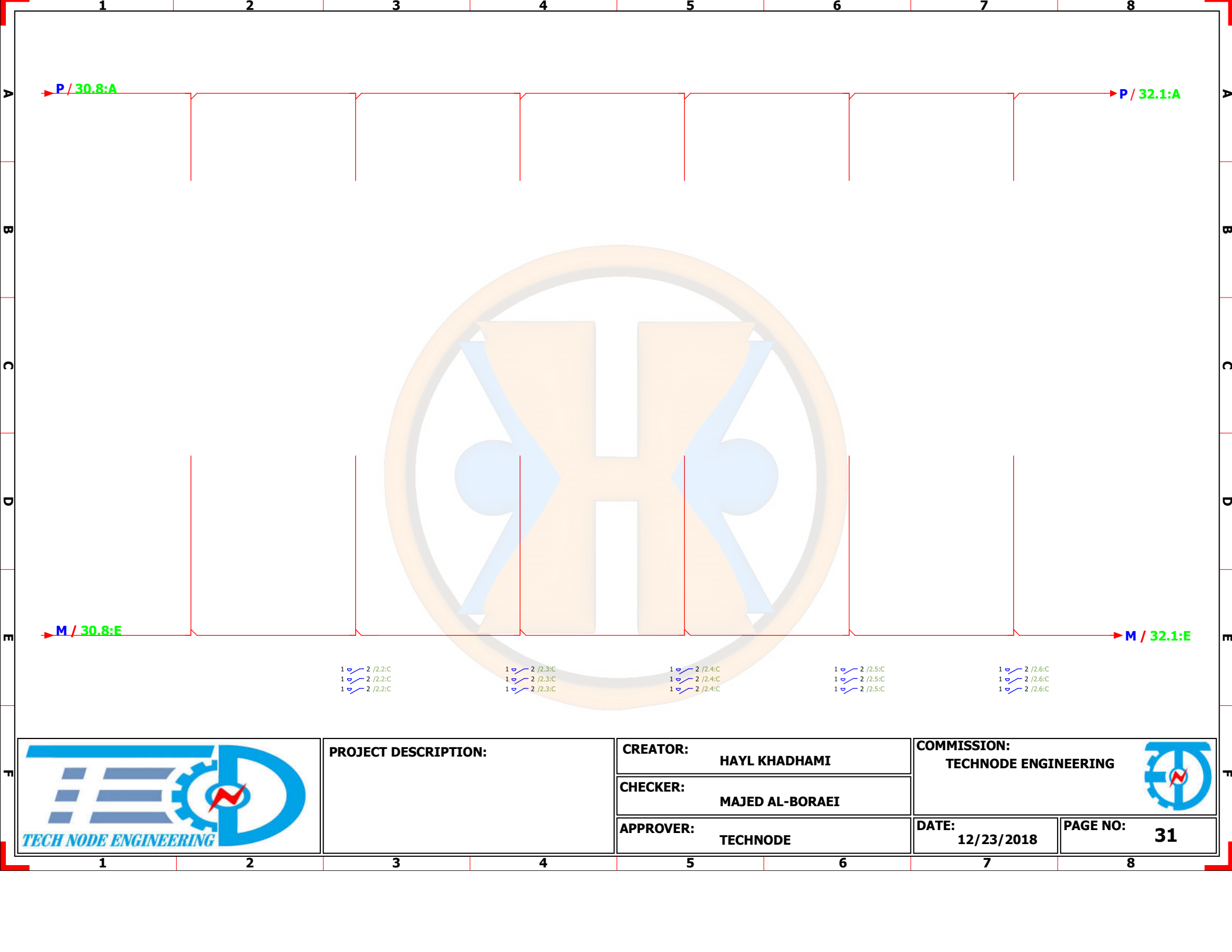

**PROJECT DESCRIPTION:**

**CREATOR:** HAYL KHADHAMI  
**CHECKER:** MAJED AL-BORAEI  
**APPROVER:** TECHNODE

**COMMISSION:** TECHNODE ENGINEERING   
**DATE:** 12/23/2018  
**PAGE NO:** 31

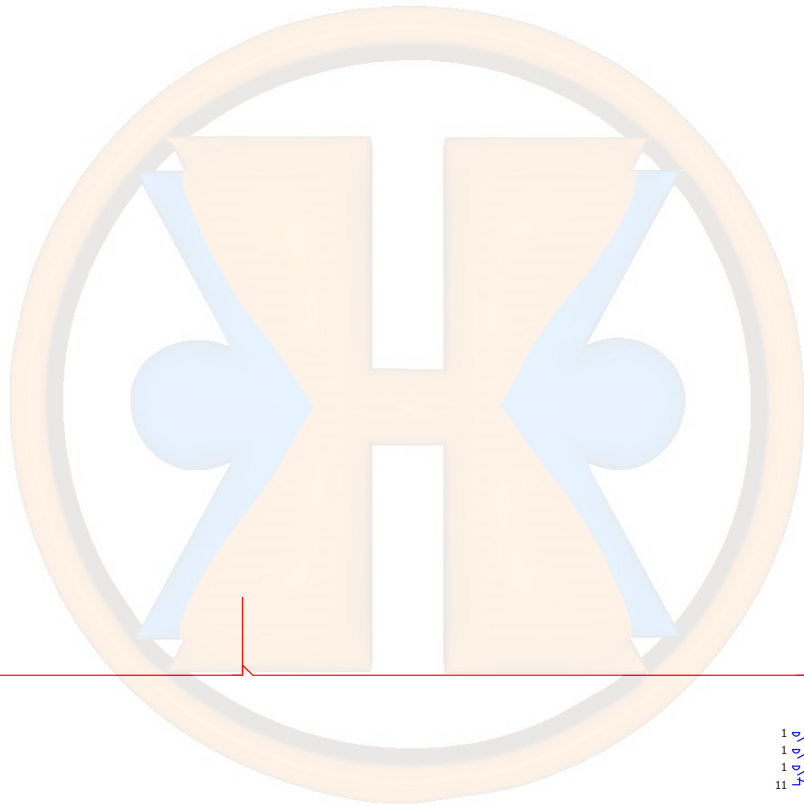

P / 31.8:A

P / 33.1:A

M / 31.8:E

M / 33.1:E

1 2 /2.7:C  
1 2 /2.7:C  
1 2 /2.7:C

1 2 /1.7:C  
1 2 /1.7:C  
1 2 /1.7:C  
11 12 /32.7:D

1 2 /1.6:C  
1 2 /1.6:C  
1 2 /1.6:C  
11 12 /32.6:D



**PROJECT DESCRIPTION:**

**CREATOR:** HAYL KHADHAMI  
**CHECKER:** MAJED AL-BORAEI  
**APPROVER:** TECHNOD

**COMMISSION:** TECHNOD ENGINEERING  
**DATE:** 12/23/2018  
**PAGE NO:** 32





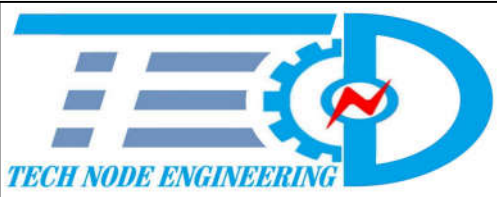
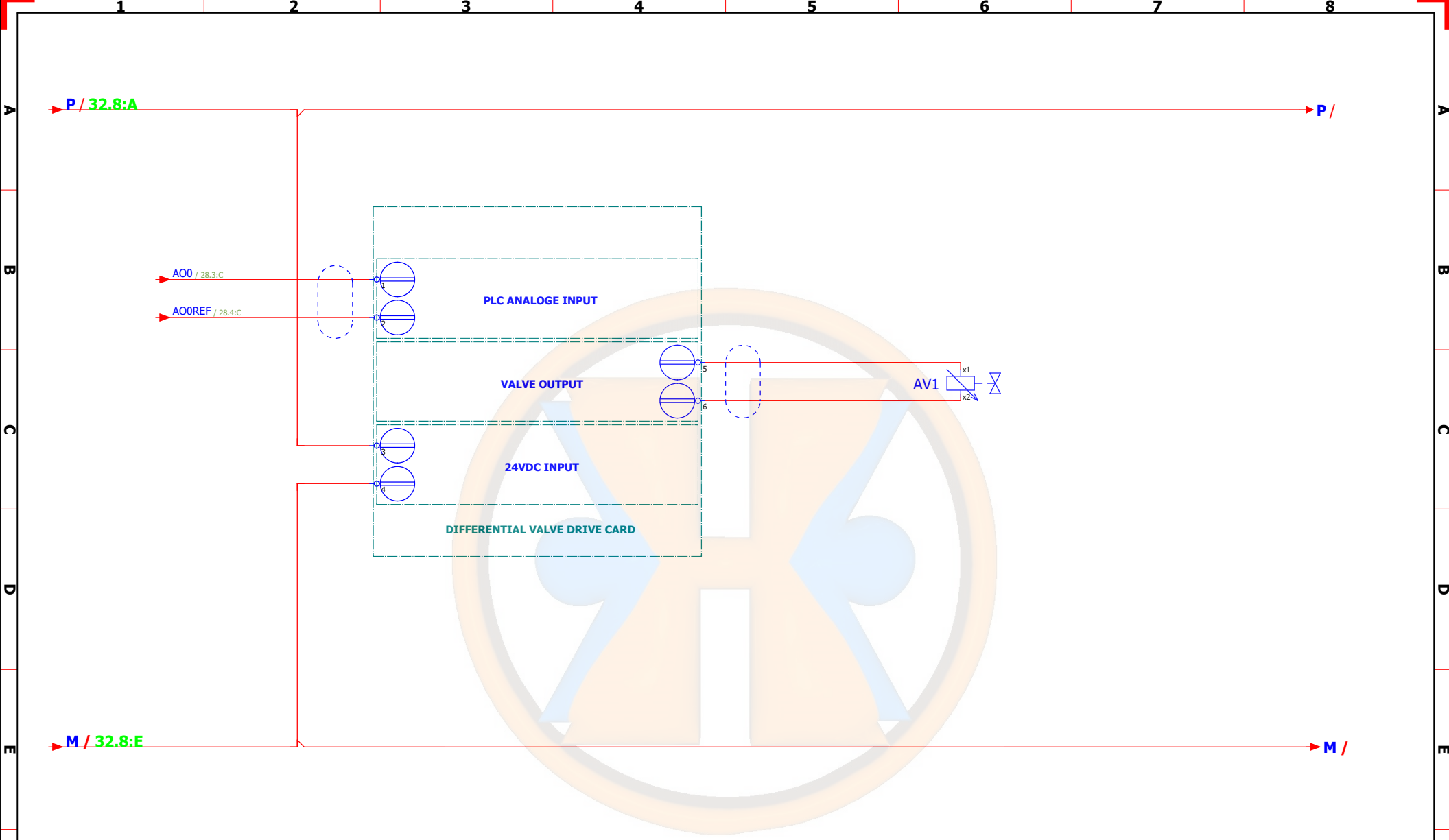

**PROJECT DESCRIPTION:**

**CREATOR:** HAYL KHADHAMI  
**CHECKER:** MAJED AL-BORAEI  
**APPROVER:** TECHNOD

**COMMISSION:** TECHNOD ENGINEERING  
**DATE:** 12/23/2018  
**PAGE NO:** 33



# Parts list

F01\_001-Copy

Device tag	Quantity	Designation	Type number	Supplier	Part number
-AH1	0				
-AL1	0				
-AV1	0				
-B1	0				
-B2	0				
-B3	0				
-B4	0				
-B5	0				
-B6	0				
-CB1	0				
-CB2	0				
-CB3	0				
-CB4	0				
-CB5	0				
-CB6	0				
-CB7	0				
-CB8	0				
-CB9	0				
-CB10	0				
-CB11	0				
-CB12	0				
-CB13	0				
-CB14	0				
-CB15	0				
-CB16	0				
-CB17	0				
-CBM1	0				
-ES1	0				
-FS1	0				
-HE1	0				
-HE2	0				
-HE3	0				
-HE4	0				
-HE5	0				
-HE6	0				
-KM1	0				
-KM2	0				
-KM3	0				
-KMB	0				
-KM4F	0				
-KM5	0				
-KM6	0				
-KM7	0				
-KM8	0				
-KM9	0				
-KM10	0				
-LS1	0				
-LS2	0				
-LS3	0				
-LS4	0				
-LSS	0				
-M1	0				

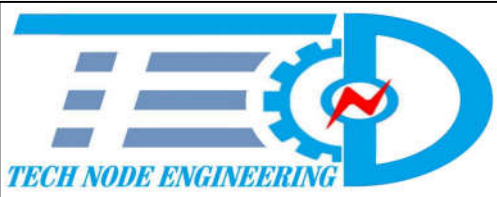

**PROJECT DESCRIPTION:**

**CREATOR:** HAYL KHADHAMI

**CHECKER:** MAJED AL-BORAEI

**APPROVER:** TECHNODE

**COMMISSION:** TECHNODE ENGINEERING



**DATE:** 12/23/2018

**PAGE NO:** 34

# Parts list

F01\_001-Copy

Device tag	Quantity	Designation	Type number	Supplier	Part number
-M2	0				
-MCB	0				
-ML1	0				
-PS1	0				
-PS2	0				
-PS3	0				
-PS4	0				
-PS5	0				
-PSU1	0				
-PSU2	0				
-R1	0				
-R2	0				
-R2A	0				
-R2B	0				
-R2C	0				
-R2D	0				
-R2E	0				
-R2F	0				
-R3	0				
-R3A	0				
-R3B	0				
-R3C	0				
-R3D	0				
-R3E	0				
-R3F	0				
-R4	0				
-R20	0				
-R21	0				
-R22	0				
-R23	0				
-R24	0				
-R25	0				
-R26	0				
-R27	0				
-R28	0				
-R29	0				
-R30	0				
-R31	0				
-R32	0				
-R33	0				
-R34	0				
-R35	0				
-R36	0				
-R37	0				
-R38	0				
-R39	0				
-SC1	0				
-SS2P1	0				
-SS2P2	0				
-SS3P1	0				
-SS3P2	0				
-SS3P3	0				

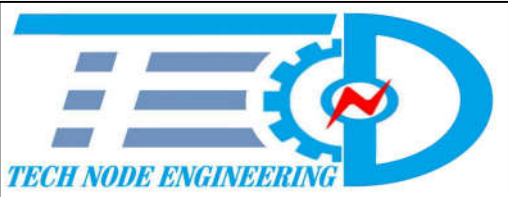

**PROJECT DESCRIPTION:**

**CREATOR:** HAYL KHADHAMI

**CHECKER:** MAJED AL-BORAEI

**APPROVER:** TECHNODE

**COMMISSION:** TECHNODE ENGINEERING



**DATE:** 12/23/2018

**PAGE NO:** 34.a

# Parts list

Device tag	Quantity	Designation	Type number	Supplier	Part number
-SS3P4	0				
-SV1	0				
-SV2	0				
-SV3	0				
-SV4	0				
-SV5A	0				
-SV5B	0				
-SV6A	0				
-SV6B	0				
-SV7	0				
-SV8	0				
-SV9	0				
-SV10A	0				
-SV10B	0				
-T1	0				

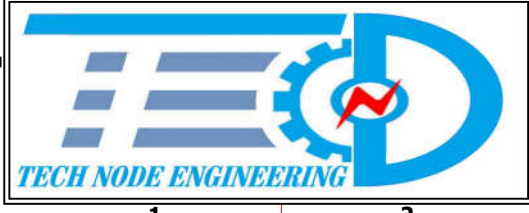
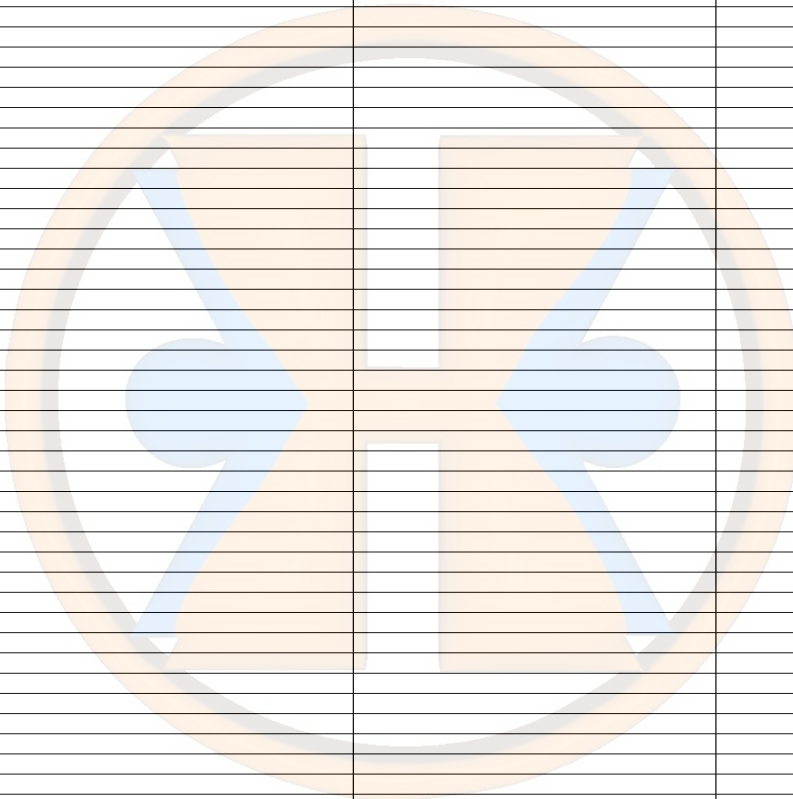

**PROJECT DESCRIPTION:**

**CREATOR:** HAYL KHADHAMI

**CHECKER:** MAJED AL-BORAEI

**APPROVER:** TECHNOD

**COMMISSION:** TECHNOD ENGINEERING



**DATE:** 12/23/2018

**PAGE NO:** 34.b